

MODEL 310.CO₂



SPECIFICATIONS	U.S. Measure	Metric Measure
Flow	1.75 gpm	6.62 lpm
Pressure Range	400–2200 psi	28–152 bar
Pump RPM*	450	450
Inlet Pressure Range**	300–400 psi	21–27.5 bar
Min. Liquid Temperature	-20° F	-29° C
Bore	0.787"	20 mm
Stroke	0.709"	18 mm
Crankcase Capacity	18 oz	.055 l

SPECIFICATIONS	U.S. Measure	Metric Measure
Inlet Ports (2)	1/2" NPT(F)	1/2" NPT(F)
Discharge Ports (2)	3/8" NPT(F)	3/8" NPT(F)
Shaft Diameter	0.787"	20 mm
Pulley Mounting	Either Side	Either Side
Weight	19.8 lbs	9 kg
Dimensions	11.73 x 10.0 x 5.24"	298 x 254 x 133 mm

* Pump minimum is 100 RPM

** Temperature and pressure must be maintained to keep incoming CO₂ in a liquid state.

EXPLODED VIEW

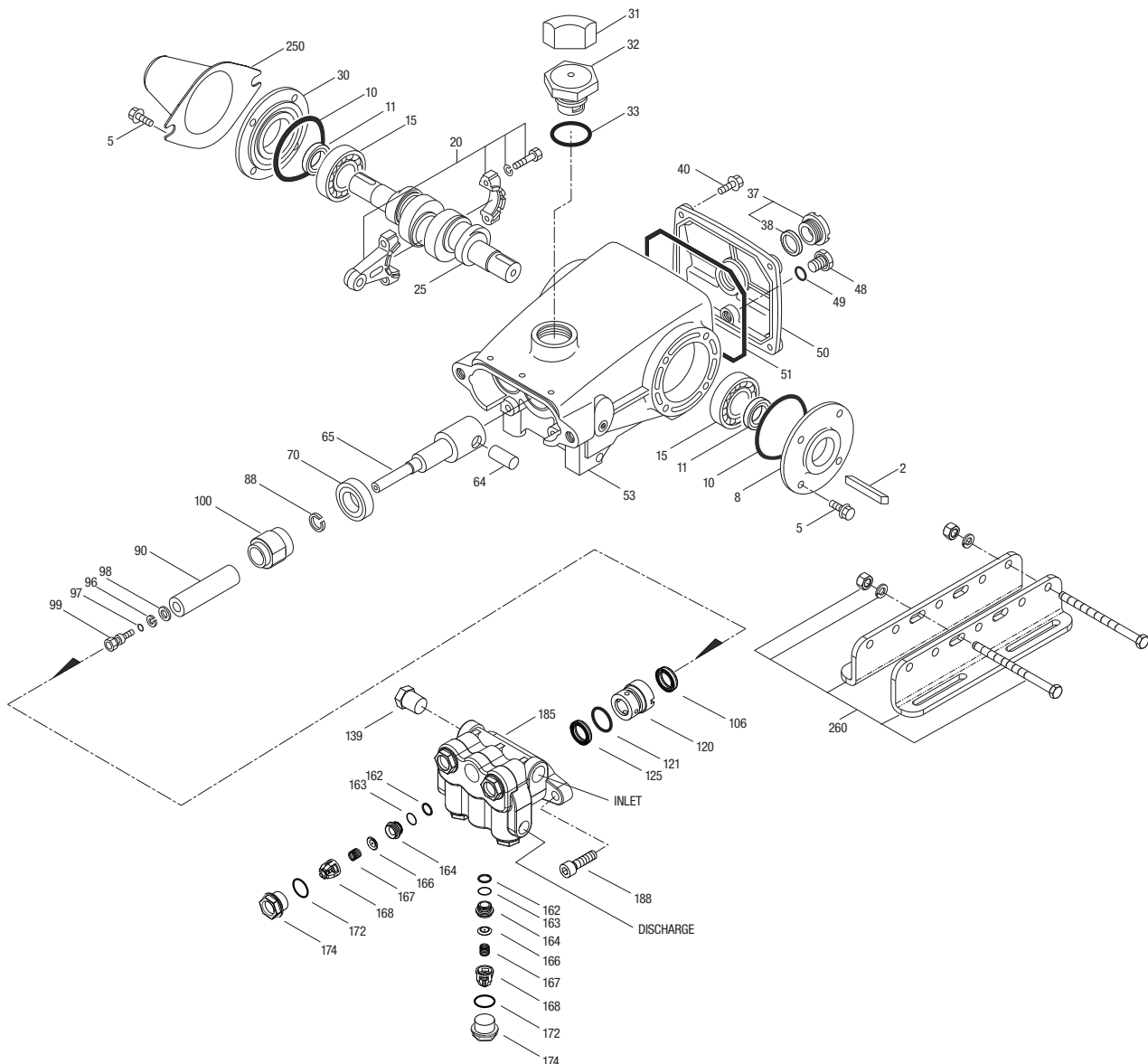

(Parts List on Reverse Side)

April 2020

PARTS LIST

ITEM PN	MATL	DESCRIPTION	QTY
2	30057	STL Key (M6 x 6 x 25) (See Tech Bulletin 074)	1
5	125824	STCP R Screw, HHC Sems (M6 x 16)	8
8	43344	AL Covering, Bearing	2
10	43343	NBR O-Ring, Bearing Cover-70D	2
11	43222	NBR Seal, Oil, Crankshaft	2
15	14480	STL Bearing, Ball	2
20	45883	HS Rod, Connecting Assembly (See Tech Bulletin 074)	3
25	43342	FCM Crankshaft, Dual End (M18)	1
31	828710	PE Protector, Oil Cap with Polyurethane Gasket	1
32	43211	ABS Cap, Oil Filler	1
33	14177	NBR O-Ring, Oil Filler Cap-70D	1
37	92241	PC Gauge, Oil, Bubble with Gasket (See Tech Bulletin 074)	1
38	44428	NBR Gasket, Flat, Oil Gauge	1
40	126541	STCP R Screw, HHC Sems (M6 x 20) (See Tech Bulletin 074)	4
48	25625	STCP Plug, Drain (1/4" x 19 BSP)	1
49	23170	NBR O-Ring, Drain Plug-70D	1
50	48772	AL Cover, Rear (See Tech Bulletin 090)	1
51	48773	NBR O-Ring, Rear Cover-70D (See Tech Bulletin 090)	1
53	48769	AL Crankcase (See Tech Bulletin 090)	1
64	43351	CM Pin, Crosshead	3
65	43365	ZZCP Rod, Plunger	3
70	43228	NBR Seal, Oil, Crankcase	3
88	45697	S Washer, Keyhole (M18 x 10)	3
90	43367	CC Plunger (M20 x 72)	3
96	43235	PTFE Backup Ring, Plunger Retainer	3
97	17399	NBR O-Ring, Plunger Retainer-80D	3

ITEM PN	MATL	DESCRIPTION	QTY
98	45891	CU Gasket, Plunger Retainer	3
99	104360	S Retainer, Plunger with stud (See Tech Bulletin 074)	3
100	701765	SS Retainer, Seal	3
106	701763	SFTA Seal, LPS with NIH-Spring	3
120	45679	BB Case, Seal	3
121	14200	NBR O-Ring, Seal Case-70D	3
125	701764	SFTA Seal, HPS with NIH-Spring	3
139	22179	BBCP Plug, Inlet (1/2" NPT(M))	1
162	48361	D Backup Ring, Seat	6
163	43358	NBR O-Ring, Seat-70D	6
164	43725	S Seat	6
166	43723	S Valve	6
167	43750	S Spring	6
168	44565	PVDF Retainer, Spring	6
172	17615	NBR O-Ring, Valve Plug-75D	6
174	43849	BBCP Plug, Valve (See Tech Bulletin 074)	6
185	44837	BBCP Head, Manifold	1
188	126520	STCP R Screw, HSH Sems (M10 x 35) (See Tech Bulletin 074)	2
250	118672	STCP Protector, Shaft	1
255	30243	STZP Mount, Direct (See Tech Bulletin 074)	1
260	30611	STZP R Mount, Rail Assembly	1
275	30944	STL Hub, "B" (35mm with keyway)	1
299	810027.C02	BBCP Head, Complete with Seals and O-Rings	1
300	76152	NBR * Kit, Seal (Includes: 97, 106, 121, 125)	1
310	30821	NBR Kit, Valve Preassembled (Includes: 162-164, 166-168, 172)	2
—	6107	— Oil, Bottle (21 oz) ISO-68 Hydraulic (Fill to Specified Crankcase Capacity Prior to Start-up)	1

*Review individual parts in each kit for material code identification.

Italics are optional items. R Components comply with RoHS Directive.

For additional technical information see www.catpumps.com/literature/tech-bulletins.

MATERIAL CODES (Not Part of Part Number): ABS=ABS Plastic AL=Aluminum BB=Brass BBCP=Brass/Chrome Plated CC=Ceramic CM=ChromeMoly CU=Copper D=Acetal
FCM=Forged Chrome-Moly HS=High Strength NBR=Medium Nitrile (Buna-N) NIH=High Nickel Alloy PC=Poly Carbonate PE=Polyethylene PTFE=Pure Polytetrafluoroethylene
PVDF=Polyvinylidene Fluoride S=304SS SS=316SS SFTA=Special Blend PTFE TAN STCP=Steel/Chrome Plated STL=Steel
STZP=Steel/Zinc Plated ZZCP=Chrome Plated/Steel-Zamak

⚠ CAUTIONS AND WARNINGS

All high-pressure systems require a primary pressure regulating device (i.e. regulator, unloader) and a secondary pressure relief device (i.e. pop-off valve, relief valve). Failure to install such relief devices could result in personal injury or damage to pump or property. Cat Pumps does not assume any liability or responsibility for the operation of a customer's high-pressure system.

Read all CAUTIONS and WARNINGS before commencing service or operation of any high-pressure system. The CAUTIONS and WARNINGS are included in each Service Manual and with each Accessory Data sheet. CAUTIONS and WARNINGS can also be viewed online at www.catpumps.com/dynamic-literature/cautions-and-warnings or can be requested directly from Cat Pumps.

WARRANTY

View the Limited Warranty online at www.catpumps.com/literature/cat-pumps-limited-warranty