

# DATA SHEET

## 35 FRAME PLUNGER PUMPS



**Brass Model: 3535.44101**

**Stainless Steel Model: 3531D.44101**

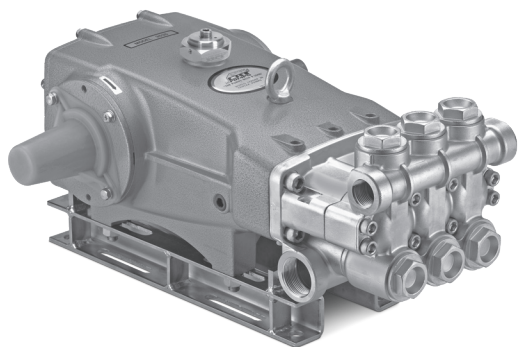

Model 3531D.44101 Shown  
(Shaft protector included, mounting rails sold separately)

### FEATURES

- Field- tested, high pressure triplex pump configured for high-temperature TEG (triethylene glycol) applications up to 240° F/115° C. May be used in other high-temperature applications with fluids possessing adequate lubrication properties. Contact Cat Pumps for more information.
- Positive displacement technology for optimum energy efficiency.
- TEG\* pump configuration option consists of following modifications:
  - FPM elastomers and O-ring material throughout the pump.
  - Stainless steel vented oil filler cap assembly.
  - Stainless steel sight gauge assembly and aluminum adapter.
  - Aluminum seal retainers.
  - Special PTFE blended low-pressure seals and V-packings.

\* TEG pump configuration is denoted by adding ".44101" to the end of the pump model.

SPECIFICATIONS	U.S.	Metric
Flow	36 gpm	136 lpm
Pressure Range	100–1200 psi	6.9–83 bar
Pump RPM*	800 rpm	800 rpm
Inlet Pressure Range	Flooded to 70 psi	Flooded to 4.8 bar
Maximum Liquid Temperature	240° F	115° C
Bore	1.575"	40 mm
Stroke	1.890"	48 mm
Crankcase Capacity	4.2 qts	4 l
Inlet Ports (2)	1½" NPT(F)	1½" NPT(F)
Discharge Ports (2)	1" NPT(F)	1" NPT(F)
Pulley Mounting	Either Side	Either Side
Shaft Diameter	1.378"	35 mm
Weight	139 lbs	63 kg
Dimensions (3535.44101)	24.33 x 18.11 x 10.17"	618 x 460 x 258 mm
Dimensions (3531D.44101)	23.89 x 18.11 x 10.17"	607 x 460 x 258 mm

\*Pump minimum is 100 RPM.

### ELECTRIC HORSEPOWER REQUIREMENTS

FLOW		PRESSURE						PUMP RPM
GPM	LPM	PSI	BAR	PSI	BAR	PSI	BAR	
		800	55	1000	69	1200	83	
		Horsepower						
36	136	19.8 hp		24.7 hp		29.7 hp		800
30	114	16.5 hp		20.6 hp		24.7 hp		667
25	95	13.7 hp		17.2 hp		20.6 hp		556

<b>DETERMINING THE PUMP RPM</b>	$\frac{\text{Rated gpm}}{\text{Rated rpm}}$	=	$\frac{\text{Desired gpm}}{\text{Desired rpm}}$
<b>DETERMINING THE REQUIRED HP</b>	$\frac{\text{hp (Electric Brake)}}{\text{Motor Pulley OD}} \times \text{Pump rpm}$	=	$\frac{\text{gpm} \times \text{psi}}{1460}$
<b>DETERMINING MOTOR PULLEY SIZE</b>	$\frac{\text{Motor Pulley OD}}{\text{Pump rpm}}$	=	$\frac{\text{Pump Pulley OD}}{\text{Motor rpm}}$

Refer to pump **Service Manual** for repair procedure and additional technical information.

## PARTS LIST

ITEM	P/N 3531D.44101	MATL	P/N 3535.44101	MATL	DESCRIPTION	QTY
5	96049	S	96049	S	Screw, HHC Sems (M10 x 25) (See Tech Bulletin 074, 125)	8
8	134604	ALE	134604	ALE	Cover, Bearing (See Tech Bulletin 118, 125)	2
9	815279	FBR	815279	FBR	Shim, Split, 2-Piece (See Tech Bulletin 125)	2
10	76173	FPM	76173	FPM	O-Ring, Bearing Cover	2
11	76172	FPM	76172	FPM	Seal, Oil, Crankshaft	2
12	855049	S	855049	S	Shim, Split, 2-Piece	0-2
15	29326	STL	29326	STL	Bearing, Roller	2
20	121467	TNM	121467	TNM	Rod, Connecting Assembly (Includes: 21, 22, 23)	3
21	126749	STCP R	126749	STCP R	Washer, Locking	3
22	126593	STCP R	126593	STCP R	Shim, Washer (M10.5)	6
23	122045	STZP	122045	STZP	Screw, HH (M10 x 55) (See Tech Bulletin 074)	6
25	29325	FCM	29325	FCM	Crankshaft, Dual End (M48)	1
32	997574	S	997574	S	Cap, Filler with O-Ring	1
34	126743	STCP R	126743	STCP R	Bolt, Eye (M12 x 1.75) (For Lifting Pump Only)	1
36	76792	SS	76792	SS	Gauge, Sight	1
37	76791	AL	76791	AL	Adapter, Sight	1
38	44428	NBR	44428	NBR	Gasket, Flat, Adapter-80D	1
40	125753	S	125753	S	Screw, HHC Sems (M8 x 25) (See Tech Bulletin 074)	8
48	25625	STCP	25625	STCP	Plug, Drain (1/4" x 19 BSP)	1
49	30322	FPM	30322	FPM	O-Ring, Drain Plug	1
50	45936	ALE	45936	ALE	Cover, Rear (See Tech Bulletin 118)	1
51	76174	FPM	76174	FPM	O-Ring, Rear Cover-75D	1
53	134784	ALE	134784	ALE	Crankcase Assembly (Includes: 34, 54) (See Tech Bulletin 118, 125)	1
54	27488	S	27488	S	Pin, Guide	2
64	43864	CM	43864	CM	Pin, Crosshead	3
65	45116	SSZZ †	45116	SSZZ	Rod, Plunger	3
69	126587	STCP R	126587	STCP R	Washer, Oil Seal	3
70	44739	FPM	44739	FPM	Seal, Oil, Crankcase	3
75	43865	S	43865	S	Slinger, Barrier	3
88	45676	S	45676	S	Washer, Keyhole	3
90	43921	CC	43921	CC	Plunger (M40 x 145)	3
95	89778	SS	89778	SS	Stud, Plunger Retainer (M10 x 135)	3
96	20189	PTFE	20189	PTFE	Backup Ring, Plunger Retainer	3
97	11375	FPM	11375	FPM	O-Ring, Plunger Retainer	3
98	44085	SS	44085	SS	Gasket, Plunger Retainer	3
99	44084	SS	44084	SS	Retainer, Plunger (M10) (See Tech Bulletin 074)	3
100	999324	AL	999324	AL	Retainer, Seal	3
106	<b>701066</b>	SFTB	<b>76398</b>	ST4	Seal, LPS with S-Spring	3
107	45381	SS	—	—	Spacer, LPS	3
110	<b>45365</b>	SS	<b>49464</b>	BBCP R	Manifold, Inlet	1
112	14183	FPM	14183	FPM	O-Ring, Inlet Manifold	3
117	44585	S	44585	S	Screw, HSH (M14 x 40) (See Tech Bulletin 074)	4
126	<b>45367</b>	SS	<b>46494</b>	BB	Adapter, Female	3
127	76780	ST4	76780	ST4	V-Packing	6
128	<b>45368</b>	SS	<b>43928</b>	BB	Adapter, Male	3
141	49519	SS	49519	SS	Spring, Coil	3
155	20137	FPM	20137	FPM	O-Ring, V-Packing Spacer-70D	3
156	20464	PTFE	20464	PTFE	Backup Ring, V-Packing Spacer	3
157	<b>49520</b>	SS	<b>49478</b>	BB	Spacer, V-Packing	3
158	20464	PTFE	20464	PTFE	Backup Ring, V-Packing Spacer	3
159	20137	FPM	20137	FPM	O-Ring, V-Packing Spacer-70D	3
162	44614	PTFE	44614	PTFE	Backup Ring, Valve Seat	6
163	14330	FPM	14330	FPM	O-Ring, Valve Seat	6
164	<b>44612</b>	SS	<b>44727</b>	S	Seat	6
166	<b>44108</b>	SS	<b>43932</b>	S	Valve	6
167	44109	SS	44109	SS	Spring	6
168	44728	PVDF	44728	PVDF	Retainer, Spring	6
170	44729	SS	44729	SS	Washer, Spring Retainer	6
171	44644	SS	44644	SS	Spring, Coil	6
172	11747	FPM	11747	FPM	O-Ring, Valve Plug-90D	6
173	20388	PTFE	20388	PTFE	Backup Ring, Valve Plug	6
174	<b>49300</b>	SSD	<b>46444</b>	FBB	Plug, Valve	6
185	<b>49299</b>	SSD	<b>49465</b>	BBCP R	Manifold, Discharge	1
188	89981	S	89981	S	Screw, HSH (M12 x 70) (See Tech Bulletin 074)	8
250	855042	NY	855042	NY	Protector, Shaft (See Tech Bulletin 125)	1

**Bold face part numbers are unique to a particular pump model**

† Production parts different from service parts. R Components comply with RoHS Directive.

For additional technical information see [www.catpumps.com/literature/tech-bulletins](http://www.catpumps.com/literature/tech-bulletins). See Service Bulletin 001.

MATERIAL CODES (Not Part of Part Number): AL=Aluminum BB=Brass BBCP=Brass/Chrome Plated CC=Ceramic CM=Chrome-Moly FBB=Forged/Brass FBR=Fiber  
 FCM=Forged Chrome-moly FPM=Fluorocarbon NBR=Medium Nitrile (Buna-N) NY=Nylon PTFE=Pure Polytetrafluoroethylene PVDF=Polyvinylidene Fluoride  
 S=304SS SFTB=Special Blend PTFE Black SS=316SS SSD=Duplex Stainless Steel STL=Steel ST4=Special PTFE4 STCP=Steel/Chrome Plated STZP=Steel/Zinc Plated  
 SSZZ=316SS/Zamak TNM=Special High Strength

# EXPLODED VIEW

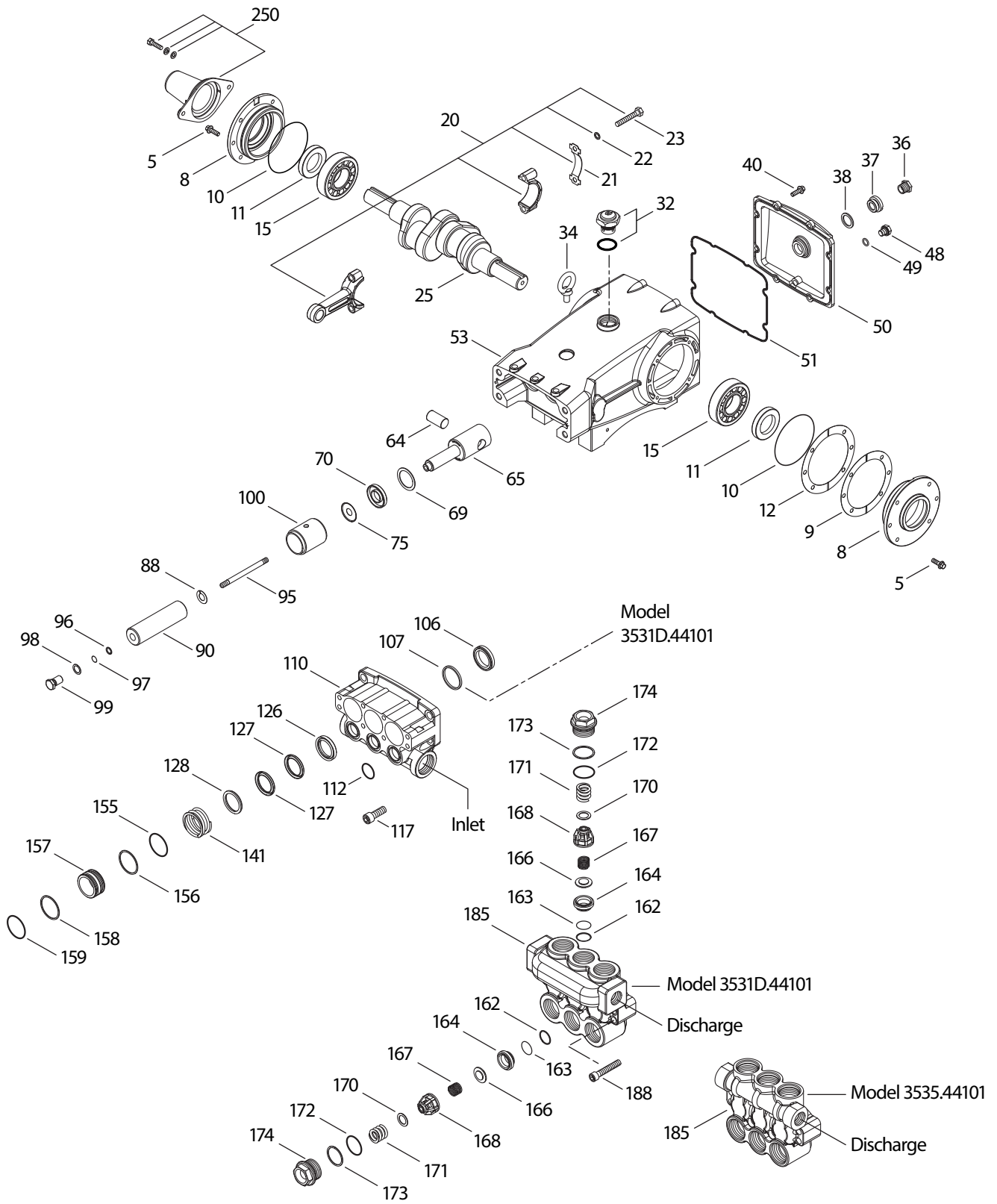

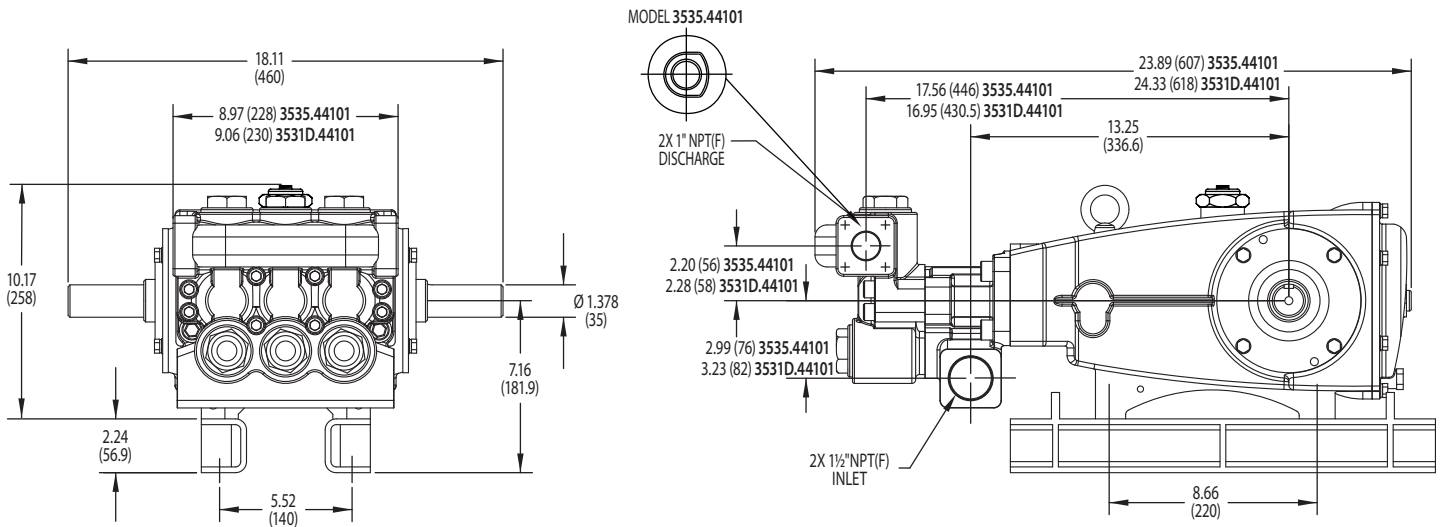

## REPAIR KITS AND PARTS

PART NUMBER	DESCRIPTION	QTY
76276 (3531D.44101)	Kit, Seal (Includes Items 97, 106, 112, 127, 155, 156, 158, 159)	1
76269 (3535.44101)		
77029 (3531D.44101)	Kit, Valve (Includes Items 162, 163, 164, 166, 167, 168, 170, 172, 173)	2
76263 (3535.44101)		
6107	Oil, Bottle (21 oz) ISO 68 Hydraulic	7
34021	Key (M10 x 8 x 70)	1
6139	Lubricant, Anti seize (8 oz) (Model 3531D.44101)	1

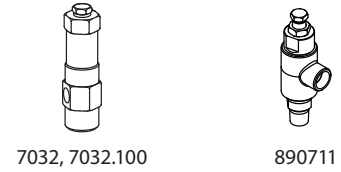

7032, 7032.100

890711



890702



6073

## OPTIONAL PARTS AND ACCESSORIES

PART NUMBER	DESCRIPTION	QTY
7032, 7032.100	Regulator (Primary Pressure Control)	1
890702	Valve, Relief (Secondary Pressure Control)	1
890711	Valve, Pop-Off (Secondary Pressure Control)	1
6073	Gauge, Pressure	1
6013	Dampener, Pulsation	1
92674	Assembly, Rail	1
76334	Kit, Oil Indicator (3/8" x 24") See Individual Data Sheet	1
34334	Kit, Oil Drain (3/8" x 24") See Individual Data Sheet	1
30696	Reverse Pliers	1
44050	Tool, Sight Gauge Removal	1



6013

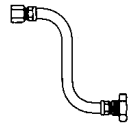

34334



6107

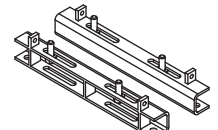

92674

### ⚠ CAUTIONS AND WARNINGS

All high-pressure systems require a primary pressure regulating device (i.e. regulator, unloader) and a secondary pressure relief device (i.e. pop-off valve, relief valve). Failure to install such relief devices could result in personal injury or damage to pump or property. Cat Pumps does not assume any liability or responsibility for the operation of a customer's high-pressure system. Read all CAUTIONS and WARNINGS before commencing service or operation of any high-pressure system. The CAUTIONS and WARNINGS are included in each Service Manual and with each Accessory Data sheet. CAUTIONS and WARNINGS can also be viewed online at [www.catpumps.com/dynamic-literature/cautions-and-warnings](http://www.catpumps.com/dynamic-literature/cautions-and-warnings) or can be requested directly from Cat Pumps.

### WARRANTY

View the Limited Warranty online at [www.catpumps.com/literature/cat-pumps-limited-warranty](http://www.catpumps.com/literature/cat-pumps-limited-warranty)