

# DATA SHEET

## PRESSURE-SENSITIVE REGULATING UNLOADER



**Brass Model: 7620**



SPECIFICATIONS	U.S.	Metric
Flow Range	0.5–8.0 gpm	1.9–30 lpm
Pressure Range	100–3200 psi	6.9–220 bar
Maximum Temperature	195° F	90° C
Inlet Port	3/8" BSPP(M)	3/8" BSPP(M)
Discharge Port	3/8" BSPP(F)	3/8" BSPP(F)
Bypass Port	3/8" BSPP(F)	3/8" BSPP(F)
Auxiliary Port	1/4" BSPP(F)	1/4" BSPP(F)
Weight	1.3 lbs	0.59 kg
Dimensions	3.34 x 1.5 x 4.72"	85 x 38 x 120 mm

Use only at above specifications to ensure proper unloader life performance.

 This Pressure-Sensitive Regulating Unloader can be converted to a Secondary Relief Valve. See page 4 for Relief Valve conversion.

### FEATURES

- Provides system pressure control and protection for single gun (non-weep) applications.
- Maintains full system pressure while running in bypass with minimal load on pump.
- Compact size allows for easy installation.
- Auxiliary port accommodates convenient gauge installation.
- Optional handle permits easy adjustment of pressure.

## Read all CAUTIONS and WARNINGS before commencing service or operation of any high-pressure system

### SELECTION

This pressure-sensitive regulating unloader is designed for systems with single pumps, solenoid (gate) valves, nozzles. "Weep" guns are not recommended with this unloader.

**Note:** For multiple-pump systems, it is best to use a pressure regulator, not a pressure-sensitive regulator unloader.

This unloader should meet both the desired system flow (combined nozzle flow rate requirement) and the designed system pressure.

**Notice:** Operation below the minimum flow of the unloader causes the unloader to cycle. Operation above the maximum flows of the unloader causes premature unloader wear, cycling and prevents attaining desired system pressure.

### INSTALLATION

This unloader operates properly when mounted in any direction. However, keeping the plumbing to a minimum and the adjusting cap or handle easily accessible is preferred. The preferred mounting location is directly on the pump's discharge manifold.

The inlet connection is a 3/8" BSP(M) sized port. Arrow and the word "IN" are cast into the body indicates the direction of flow. Liquid from the discharge of the pump goes into this connection.

The discharge connection is a 3/8" BSP(F) sized port. An arrow and the word "OUT" are cast into the body indicates the direction of flow. Plumbing to the spray guns, solenoid (gate) valves or nozzles connect here.

The bypass connection is a 3/8" BSP(F) sized port. An arrow and the word "BY PASS" is cast into the body indicates the direction of flow. Bypass liquid is directed out of this port and can be routed to a reservoir (preferred method), drain or to the pump inlet.

The auxiliary connection is a 1/4" BSP(F) sized port and is located on the side. A pressure gauge can be mounted to this port, or it can be plugged.

### OPERATION

This pressure-sensitive regulating unloader holds established system pressure in the discharge line when the trigger gun or solenoid (gate) valve is closed, or the nozzle is clogged, thus bypassing all unrequired flow. Squeezing the trigger gun or opening the solenoid (gate) valve will close the bypass and return to established system pressure.

### PRESSURE ADJUSTMENT

**Note:** Pressure is not set at the factory.

1. Setting and adjusting the unloader pressure must be done while the system is running.
2. Start the system with unloader backed off to the lowest pressure setting (counterclockwise direction).
3. Increase the unloader pressure setting by turning the adjusting cap clockwise.
4. Squeeze the trigger and read the pressure on the gauge at the pump.

**Note:** Do not read the pressure at the gun or nozzle.

5. If more pressure is desired, release the trigger, turn adjusting cap one quarter turn in clockwise direction.
6. Squeeze the trigger and read the pressure.
7. Repeat this process until desired system pressure is reached.

**Notice:** A minimum of 5% of the flow through the unloader should bypass for proper unloader performance. If the entire unloader flow pumps through the nozzle (zero bypass), the valve can easily be set for pressure higher than the desired pressure, causing a malfunction or premature wear.

8. If desired system pressure cannot be reached, review TROUBLESHOOTING chart.

**Note:** Do not adjust unloader pressure setting to compensate for a worn nozzle. Check the nozzle as part of the regular maintenance and replace if worn.

**Note:** A secondary pressure safety relief device (e.g. Pop-Off Valve, safety valve) should be used along with this pressure-sensitive regulating unloader. Final adjustment for the relief valve should relieve at 200 psi above the system operating pressure.

**Note:** By removing the check valve and spring, this unloader can function as a secondary relief valve.

 See page 4 for Relief Valve conversion.

### TYPICAL UNLOADER INSTALLATION

1. Pressure Gauge
2. Pop-Off Valve  
Shown as a Secondary Safety Relief Valve
3. **Pressure-Sensitive Regulating Unloader**
4. Triplex Plunger Pump

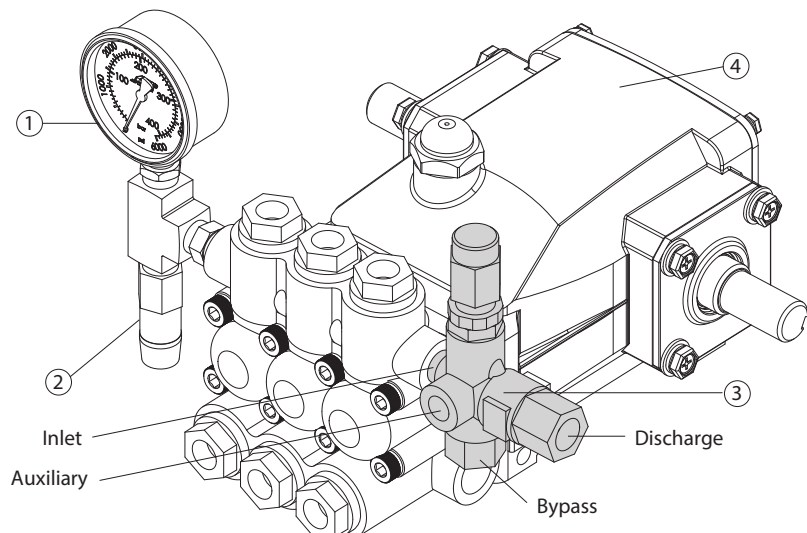

## Read all CAUTIONS and WARNINGS before commencing service or operation of any high-pressure system

### SERVICING

#### Disassembly

1. Disconnect bypass, discharge and inlet plumbing from unloader.
2. Remove unloader from pump.
3. Secure body of unloader in a vise with hex adjusting cap facing up.
4. Remove discharge fitting and O-ring, spring, check valve and O-ring.
5. Examine check valve and discharge fitting for wear, spring for wear or fatigue and O-rings for cuts or wear and replace as needed.

**Note:** While the discharge fitting is removed, inspect sealing area where the check valve makes contact within the internal body of the unloader for grooves, pitting and wear. If damage is found, stop the repair and replace with complete new unloader. If not, proceed with disassembly.

6. If supplied with a lock nut, the lock nut does not need to be removed. Turn lock nut down towards unloader body.
7. Remove hex adjusting cap by turning in a counterclockwise direction.
8. Remove spring and spring retainer.
9. Examine spring and spring retainer for scale build up, fatigue or wear and replace as needed.
10. Remove bypass fitting with O-ring from bottom port.
11. Remove seat with O-ring from the male threaded side of bypass fitting.
12. Examine seat for scale build up, scoring and wear and replace as needed. Examine O-ring for cuts or wear and replace as needed.
13. Removal of piston stem and valve/ball assembly requires the use of a small hex socket and screwdriver. Insert screwdriver from the top and place in slotted head of piston stem. Insert small hex socket into bottom port and secure valve/ball assembly. Unthread by turning in a counterclockwise direction.
14. Examine piston stem and valve/ball assembly for scale build up, scoring, pitting and wear and replace as needed. Examine O-rings and backup ring for cuts or wear and replace as needed.
15. Remove piston retainer with o-rings and backup rings by turning in a counterclockwise direction.
16. Examine piston retainer for wear. Examine O-rings and backup ring for cuts or wear and replace as needed.

#### Reassembly

1. Lubricate and install small body backup ring and then body O-ring into unloader body.
2. Lubricate and install O-ring over threads of piston retainer.
3. Carefully hand thread piston retainer with small diameter hole facing down into unloader body and tighten with a wrench.
4. Lubricate and install O-ring over piston stem head and then backup ring into groove of piston stem.
5. Apply Loctite® 242® to the last few threads of the piston stem.
6. Insert piston stem from the top through the piston retainer until seated.
7. Using the same tools in removing the piston stem and valve/ball assembly, place valve/ball assembly into hex socket tool with ball surface facing down into socket. Place screwdriver tip into piston stem slotted head. Thread piston stem into valve/ball assembly.
8. Place bypass fitting on flat surface with male threads facing up.
9. Lubricate and install O-ring onto seat. Press seat into bypass fitting. Hand thread bypass fitting into lower port of unloader body and tighten with wrench.
10. Lubricate and install O-ring on discharge fitting.
11. Insert spring into discharge fitting, then insert check valve with small step end into spring. Hand thread into unloader body and tighten with wrench.
12. Place spring retainer on top of piston stem.
13. Place spring on to spring retainer.
14. Thread hex adjusting cap onto piston retainer.
15. Remove unloader from vise.
16. Re-install unloader onto pump.
17. Reconnect bypass, discharge and inlet plumbing to unloader.
18. Proceed to PRESSURE ADJUSTMENT.

Loctite® and 242® are registered trademarks of the Henkel Corporation.

### TROUBLESHOOTING

Unloader cycles	<ul style="list-style-type: none"> <li>• Worn O-ring or check valve</li> <li>• Fitting leaking downstream</li> <li>• Air in system, poor connection</li> </ul>	<ul style="list-style-type: none"> <li>• O-ring in gun worn</li> <li>• Insufficient flow through unloader</li> </ul>
Liquid leaking from bottom	<ul style="list-style-type: none"> <li>• O-ring for seat or inlet fitting cut or worn</li> </ul>	<ul style="list-style-type: none"> <li>• O-ring for seat cut or worn</li> </ul>
Liquid leaking from middle	<ul style="list-style-type: none"> <li>• O-ring for piston cut or worn</li> </ul>	<ul style="list-style-type: none"> <li>• O-rings for piston stem cut or worn</li> </ul>
Unloader will not come up to pressure	<ul style="list-style-type: none"> <li>• Not properly sized for system pressure</li> <li>• Foreign material in unloader</li> <li>• Piston stem O-rings worn</li> </ul>	<ul style="list-style-type: none"> <li>• Nozzle worn or too large</li> <li>• Insufficient flow to pump</li> </ul>
Extreme pressure spikes	<ul style="list-style-type: none"> <li>• Adjusting handle turned completely into unloader</li> <li>• Restricted bypass or no bypass</li> </ul>	<ul style="list-style-type: none"> <li>• System flow exceeds unloader rating</li> </ul>
Filtration	<ul style="list-style-type: none"> <li>• Clean filter on regular schedule to avoid cavitation</li> </ul>	

## PARTS LIST

ITEM	PN	MATL	DESCRIPTION	QTY
401	32088	NY	Handle, Adjusting, Black	1
402	33859	BB	Cap, Adjusting	1
403	33857	BB	Nut, Locking (M18 x 1)	1
404	33061	STZP	Screw, Set (M4 x 4)	1
408	—	STZP	Spring (Silver)	1
410	32819	STZP	Spring, Guide	1
412	33860	S	Stem, Valve with O-Ring and Backup Ring	1
425	33861	BB	Retainer, Piston	1
428	—	NBR	O-Ring, Retainer	1
429	—	NBR	O-Ring, Stem	1
430	—	PTFE	Backup Ring, Stem	1
435	33853	SSS	Valve and Ball Assembly	1
436	33806	S	Seat with NBR O-Ring	1
440	—	BB	Body, Valve	1
442	—	NBR	O-Ring, Bypass Fitting–85D	1
443	76736	BB	Valve, Check with O-Ring	1
444	33843	S	Spring, Valve, Check	1
446	—	NBR	O-Ring, Discharge Fitting	1
455	33846	BB	Fitting, Bypass [ $\frac{3}{8}$ " BSP(F)]	1
460	33847	BB	Fitting, Discharge [ $\frac{3}{8}$ " BSP(F)]	1
468	76781	NBR	Kit, O-Ring (Includes: 414, 415, 428–430, 442, 446)	1

*Italics are optional items.*

MATERIAL CODES (Not Part of Part Number): BB=Brass NBR=Medium Nitrile (Buna-N) NY=Nylon PTFE=Pure Polytetrafluoroethylene S=304SS SSS=416SS STZP=Steel/Zinc Plated

## EXPLODED VIEW

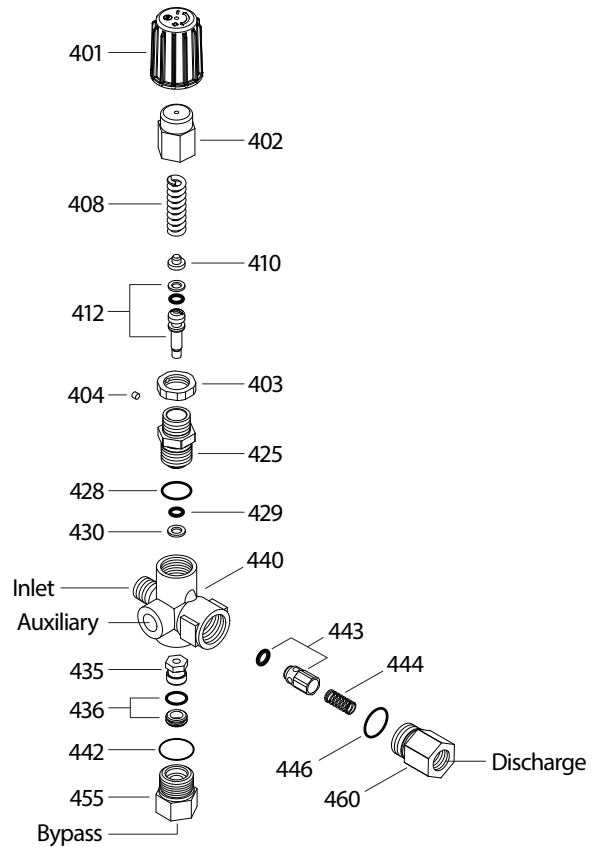

### REGULATING UNLOADER TO RELIEF VALVE CONVERSION

The 7620 Pressure-Sensitive Regulating Unloader is typically used as a primary pressure regulating device. It can be converted to a Relief Valve to be used as a secondary pressure relief device by removing the discharge check valve with O-ring and spring.

Unloader PN	Modifications	Converted Relief Valve PN
7620	Remove parts 443, 444	7620.100 (NBR Seals)

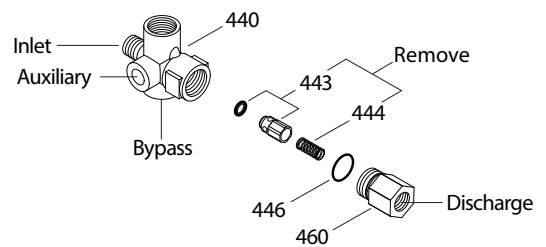

### CAUTIONS AND WARNINGS

All high-pressure systems require a primary pressure regulating device (i.e. regulator, unloader) and a secondary pressure relief device (i.e. pop-off valve, relief valve). Failure to install such relief devices could result in personal injury or damage to pump or property. Cat Pumps does not assume any liability or responsibility for the operation of a customer's high-pressure system.

Read all CAUTIONS and WARNINGS before commencing service or operation of any high-pressure system. The CAUTIONS and WARNINGS are included in each Service Manual and with each Accessory Data sheet. CAUTIONS and WARNINGS can also be viewed online at [www.catpumps.com/dynamic-literature/cautions-and-warnings](http://www.catpumps.com/dynamic-literature/cautions-and-warnings) or can be requested directly from Cat Pumps.

### WARRANTY

View the Limited Warranty online at [www.catpumps.com/literature/cat-pumps-limited-warranty](http://www.catpumps.com/literature/cat-pumps-limited-warranty)