

DATA SHEET

VERTICAL MULTISTAGE PUMP



**316 Stainless
Steel Model:**

8KS32-6E2500T3



SPECIFICATIONS

Size

Suction 300# ANSI raised face 2.50"

Discharge 300# ANSI raised face 2.50"

HP 25 hp

RPM 3450 rpm

Liquid Handled

Type of Liquid Clean Water (For Other Clean Liquids, Consult Factory)

Temperature Range 5° to +248° F (-15° to 120° C)

Working Pressure Max 440 psi (30 bar)

Materials

Impeller AISI 316

Intermediate Casing AISI 316

Bottom Casing AISI 316

Casing Cover AISI 316

Outer Casing AISI 316

Shaft AISI 316

Liner Ring PTFE/AISI 316

Motor Bracket Cast Iron/316

Base Cast Iron/316

Pump Bearing Sealed Ball Bearing/Tungsten Carbide

Mechanical Seal Silicon Carbide/Carbon/FPM

Motor

Type NEMA 284TSC Frame

Speed 60 Hz, 3450 rpm (2 Poles)

Three Phase 208-230/460V

Direction of Rotation Clockwise When Viewed from Motor End

Test Standard ISO 9906 Annex A

Weight

Pump 200 lbs

Motor 371 lbs

NOTE: See PN 99SVM001 for complete operating instructions, installation and maintenance manual information.

PERFORMANCE CURVE – 3450 RPM

185 gpm, 575 Head ft.

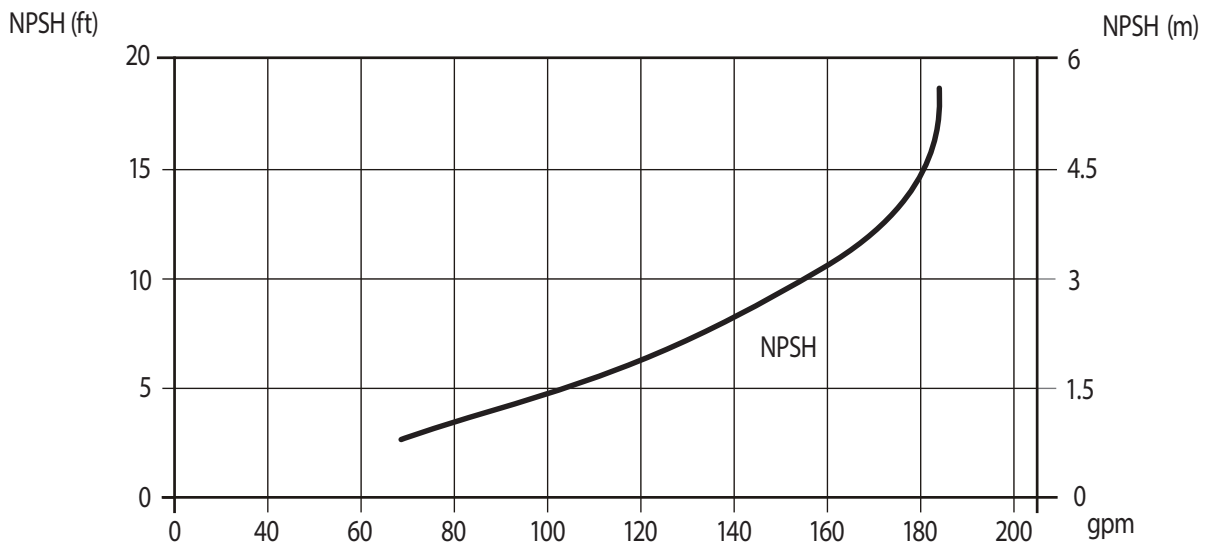
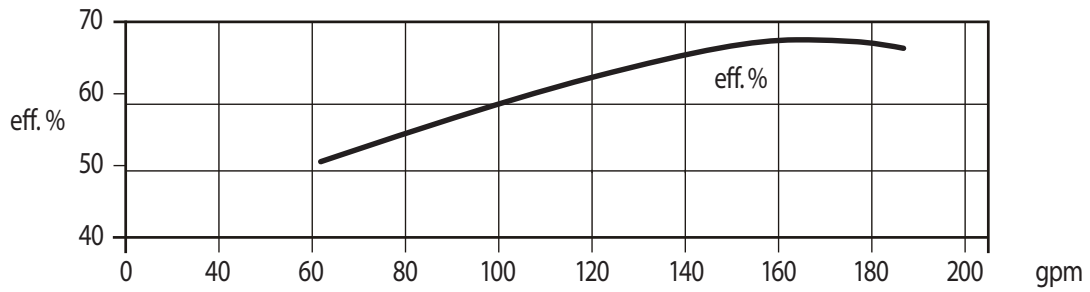
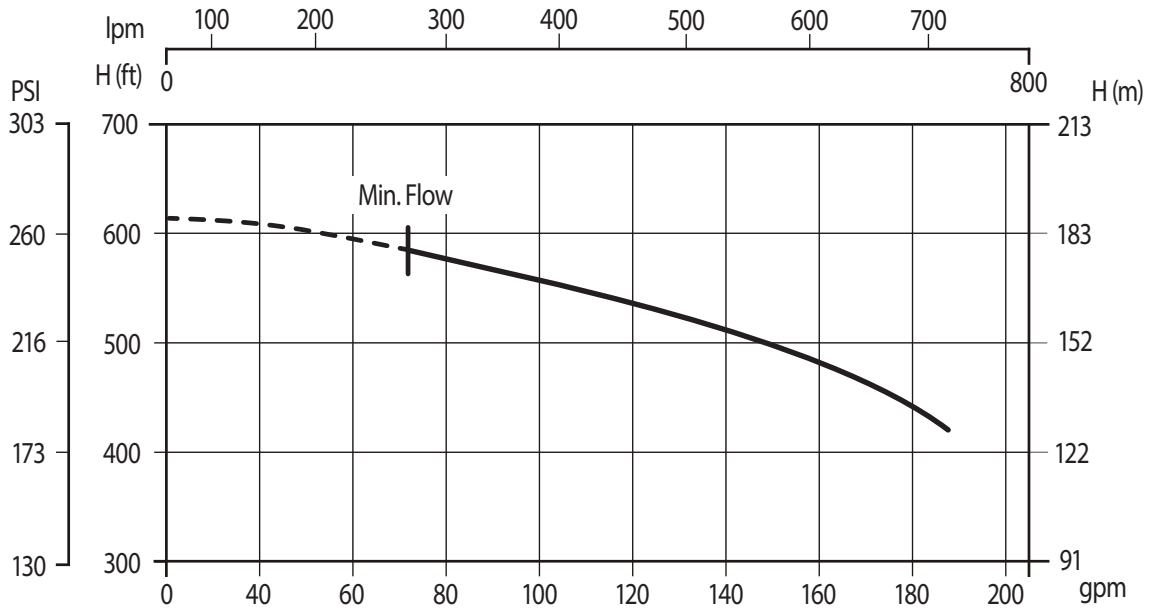

Water Temperature: 68° F (20° C)

EXPLODED VIEW

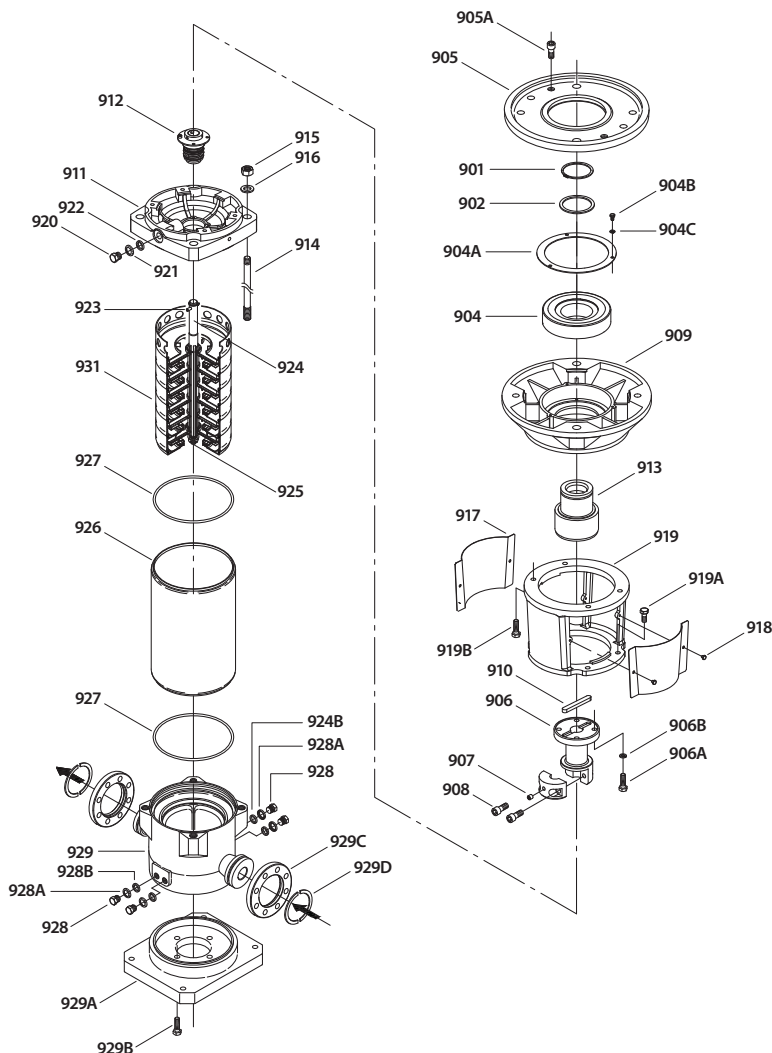

900 Motor not Shown

PARTS LIST

PART					PART				
ITEM	NUMBER	MATL	DESCRIPTION	QTY	ITEM	NUMBER	MATL	DESCRIPTION	QTY
900	—	—	Motor, Electric (Not Shown)	1	919B	—	STZP	Screw, Bearing Housing	4
901	—	STL	Ring, Snap, C-Type for Coupler	1	920	—	SS	Plug, Vent	1
902	—	STL	Spacer	1	921	—	S	Washer, Vent Plug	1
904	—	STL	Bearing, Ball	1	922	—	FPM	O-Ring, Vent Plug	1
904A	—	S	Holder, Bearing	1	923	—	STL	Pin, Shaft	1
904B	—	STZP	Screw, Bearing Holder	3	924	—	SS	Shaft	1
904C	—	STZP	Washer, Spring, Bearing holder	3	925	—	S	Nut, Impeller	1
905	—	F	Liner, Motor	1	926	—	SS	Casting, Outer	1
905A	—	STZP	Screw, Motor Liner	4	927	—	FPM	O-Ring, Outer Casing	2
906	—	STL	Coupling, Lower	1	928	—	SS	Plug, Drain	4
906A	—	STZP	Screw, Lower Coupling	4	928A	—	SS	Washer, Drain Plug	4
906B	—	STZP	Washer, Spring, Lower Coupling	4	928B	—	FPM	O-Ring, Drain Plug	4
907	—	STL	Screw, Set	1	929	—	SS	Casing, Bottom	1
908	—	STZP	Screw, Coupler	2	929A	—	F	Base	1
909	—	F	Housing, Bearing	1	929B	—	STZP	Screw, Base	4
910	—	STL	Key	1	929C	—	STL	Flange, Pump	2
911	—	F+S	Cover, Casing	1	929D	—	STL	Ring, Adjusting	2
912	—	FSC	Seal, Mechanical	1	930	899409		<i>Kit, Seal (Includes: Mechanical Seal and 2 Outer Casing O-Rings)</i>	1
913	—	STL	Coupling, Upper	1	931	—		<i>Kit, Hydraulic (Includes: Hydraulic Assembly, Upper and Lower Casing O-Rings, Pump Shaft Key, Pumps Coupling Snap Ring, Mechanical Seal)</i>	1
914	—	STZP	Rod, Tie	4					
915	—	STZP	Nut, Tie Rod	4					
916	—	STZP	Washer, Tie Rod	4					
917	—	S	Guard, Coupling	2					
918	—	S	Screw, Coupling Guard	2					
919	—	F	Bracket, Motor	1					
919A	—	S	Screw, Motor Bracket	4					

Italics are optional items

Material Codes (Not part of part number): F=Cast Iron, FPM=Fluorocarbon, FSC=FPM w/Silicon Carbide, S=304 Stainless Steel, SS=316 Stainless Steel, STL=Steel, STZP=Steel/Zinc Plated

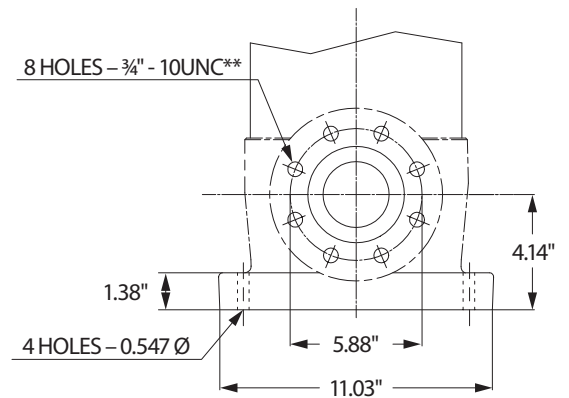
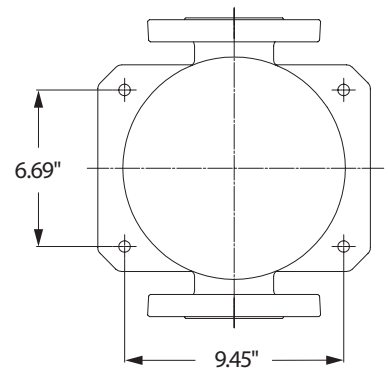
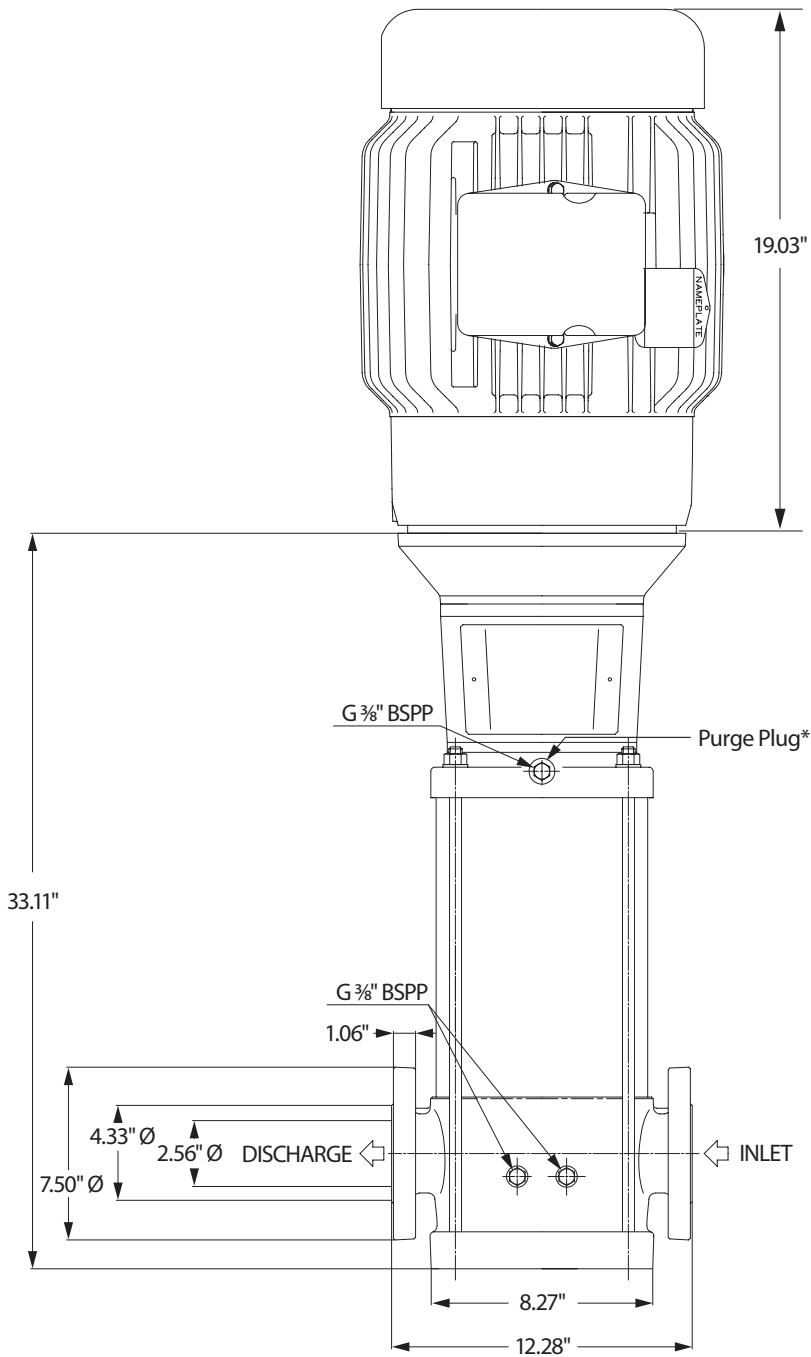

* All air must be purged out before operation to prevent seal damage.

** Flange tightening torque= 59 ft-lbs.

⚠ CAUTIONS AND WARNINGS

All high-pressure systems require a primary pressure regulating device (e.g. regulator, unloader) and a secondary pressure relief device (e.g. pop-off valve, relief valve). Failure to install such relief devices could result in personal injury or damage to pump or property. Cat Pumps does not assume any liability or responsibility for the operation of a customer's high-pressure system.

Read all CAUTIONS and WARNINGS before commencing service or operation of any high-pressure system. The CAUTIONS and WARNINGS are included in each Service Manual and with each Accessory Data sheet. CAUTIONS and WARNINGS can also be viewed online at www.catpumps.com/dynamic-literature/cautions-and-warnings or can be requested directly from Cat Pumps.

WARRANTY

View the Limited Warranty online at www.catpumps.com/literature/cat-pumps-limited-warranty