

DATA SHEET

HIGH-PRESSURE REGULATORS



Brass Models: 7080, 7082



Model Shown 7080

FEATURES

- Provides system pressure setting and protection for single or multiple gun applications.
- Compact size allows for easy installation.
- Immediately returns to system pressure when gun opens.
- Color coded spring for easy valve identification and simple change from one model to another.
- Regulators come standard with NBR O-rings. Alternate O-rings are available for higher temperatures or chemical compatibility.

SPECIFICATIONS	U.S. Measure	Metric Measure
7080		
Flow Range	2.5–8.0 gpm	9.5–30 lpm
Pressure Range	150–1450 psi	10–100 bar
7082		
Flow Range	2.5–8.0 gpm	9.5–30 lpm
Pressure Range	850–3200 psi	59–220 bar

COMMON SPECIFICATIONS	U.S. Measure	Metric Measure
Maximum Temperature (NBR)	140° F	60° C
Inlet Port	3/8" NPT(F)	3/8" NPT(F)
Discharge Port	3/8" NPT(F)	3/8" NPT(F)
Bypass Port	3/8" NPT(F)	3/8" NPT(F)
Weight	1.3 lbs	0.59 kg
Dimensions	3.1 x 2.0 x 6.4"	79 x 51 x 163 mm

ALTERNATIVE O-RING CONFIGURATION

MATERIAL	SUFFIX CODE	MAXIMUM TEMPERATURE	
NBR	—	140° F	(60° C)
FPM	.0110	240° F	(115° C)

Read all CAUTIONS and WARNINGS before commencing service or operation of any high-pressure system

SELECTION

These pressure regulators are designed for systems with single or multiple pumps, solenoid (gate) valves, nozzles and shut-off or weep guns. The pressure regulator should meet both the desired system flow (combined nozzle flow rate) and the desired system pressure.

NOTICE: Operating below the minimum rated flow of the regulator will cause cycling. Operating above the maximum rated flow of the regulator causes cycling and premature wear, preventing achievement of the desired system pressure.

INSTALLATION

These regulators operate properly mounted in any direction. However, keeping the plumbing to a minimum and the adjusting nuts easily accessible is preferred. The preferred mounting location is directly onto the pump's discharge manifold.

The inlet connection is a $\frac{3}{8}$ " NPT(F) port that is located on the bottom. There is an arrow and the word IN cast into the body indicating the direction of flow. Liquid from the discharge of the pump goes into this connection.

The discharge connection is a $\frac{3}{8}$ " NPT(F) port located on the front. Plumbing for the spray guns, solenoid (gate) valves or nozzles connect here.

The bypass connection is a $\frac{3}{8}$ " NPT(F) port located on the side. The word BY-PASS is cast into the body. Bypass liquid is directed out of this port and can be routed to a reservoir (preferred method), drain or pump inlet.

OPERATION

These pressure regulators maintain system pressure in the discharge line and at the pump head when the trigger gun or solenoid (gate) valve is closed, or the nozzles are clogged, thus bypassing all unrequired flow. Squeezing the trigger gun or opening the solenoid valve allows for a quick return to system pressure.

PRESSURE ADJUSTMENT

Note: Pressure is not set at the factory.

1. Setting and adjusting the regulator pressure must be done while the system is running.
2. Start the system with the regulator backed off to the lowest pressure setting (counterclockwise).

Note: Top nut is a locking nut and the bottom nut is the adjusting nut. The brass nut located on the piston stem inside the spring is a limit stop for the spring, do not adjust.

3. Increase the regulator pressure setting by turning the adjusting nut clockwise.
4. Squeeze the trigger and read the pressure on the gauge at the pump.

Note: Do not read the pressure at the gun or nozzle.

5. If more pressure is desired, release the trigger, turn the adjusting nut one quarter turn in a clockwise direction.
6. Squeeze the trigger and reread the pressure.
7. Once the desired system pressure is reached, stop turning the bottom adjusting nut.
8. Thread the top locking nut down to the bottom adjusting nut.

NOTICE: A minimum of 5% of the flow through the regulator should bypass for proper regulator performance. If the entire regulator flow pumps through the nozzle (zero-bypass), the valve can easily be set for pressure higher than the desired pressure, causing a malfunction or premature wear.

9. If desired system pressure cannot be reached, review TROUBLESHOOTING chart.

TYPICAL RELIEF VALVE INSTALLATION

1. Pressure Gauge
2. Relief Valve
(Secondary Pressure Relief Device)
3. **Pressure Regulator**
(Primary Pressure Regulating Device)
4. Triplex Plunger Pump

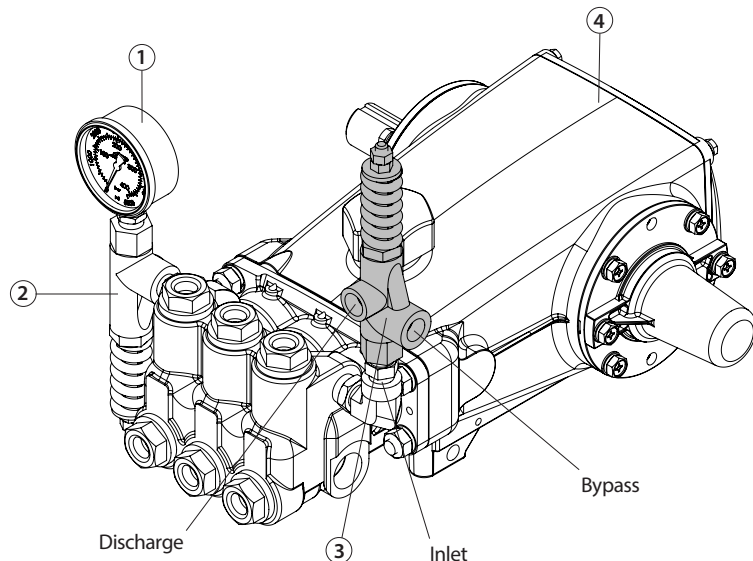

Read all CAUTIONS and WARNINGS before commencing service or operation of any high-pressure system

SERVICING

Disassembly

1. Disconnect bypass, discharge and inlet plumbing from the regulator.
2. Remove regulator from the pump.
3. Secure regulator in a vise with spring facing upwards.
4. Remove top locking nut, bottom adjustment nut, spring retainer and spring. Examine pressure spring for fatigue or breaks. Replace as needed.
5. Remove brass limit nut from piston stem.
6. Drive out piston lock pin from piston stem.
7. Using a $\frac{15}{16}$ " wrench remove piston retainer with O-ring. Examine O-ring for cuts or wear. Replace as needed.
8. Remove piston stem with two backup rings and one O-ring from regulator body. The piston retainer backup ring and O-ring will remain on the piston stem. Examine all backup rings and O-ring for cuts or wear. Replace as needed.
9. Turn regulator upside down and remove the inlet fitting with O-ring using a $\frac{15}{16}$ " wrench. Remove spring and ball. Examine O-ring for cuts or wear. Replace as needed. Examine pressure spring for fatigue or breaks. Replace as needed.

NOTICE: Exercise extreme caution to avoid contact and damage to the tapered surface of the seat.

10. Remove seat with O-ring. Examine O-ring for cuts or wear. Replace as needed. Examine seat for nicks or wear. Replace as needed.

Note: With the regulator completely disassembled, inspect the sealing area where the seat and piston retainer make contact within the regulator's lower body for grooves, pitting and wear. If damage is found, stop the repair and replace the lower body or the entire regulator. If no damage is found, proceed with the reassembly.

Reassembly

1. Place regulator body in a vise with the inlet port facing up.
2. Lubricate and install the O-ring onto the seat. Press seat with larger tapered hole facing up.
3. Install stainless steel ball onto seat.
4. Lubricate and install O-ring to inlet fitting. Place spring into small hole of inlet fitting. Thread inlet fitting into body of regulator.
5. Turn regulator over with retainer spring port facing up.
6. Lubricate and install backup ring, one O-ring and a second backup ring on machined groove of the piston stem.
7. Lubricate and install O-ring over the piston stem and then place backup ring on top of O-ring.
8. Install piston stem with tapered end down into the regulator body.
9. Install piston retainer over piston stem and thread into regulator body. Ensure that the hole in the piston stem aligns with slot in the piston retainer.
10. Press piston pin through slot in piston retainer and hole in piston stem.
11. Apply Loctite® 242® to threads of brass limit nut and thread onto piston stem. Nut should thread down to last thread on piston stem.
12. Install spring over piston stem.
13. Place spring retainer with boss side down on spring.
14. Thread on bottom adjusting nut and then top locking nut onto piston stem.
15. Re-install regulator onto pump.
16. Reconnect bypass, discharge and inlet plumbing to regulator.
17. Proceed to PRESSURE ADJUSTMENT.

Loctite and 242 are registered trademarks of the Henkel Corporation.

TROUBLESHOOTING

Excessive Pressure Fluctuations	<ul style="list-style-type: none"> • Valve is improperly set Repeat adjustment procedure • Air in system, check connections
Valve continually bypasses	<ul style="list-style-type: none"> • Seat, ball or piston stem is worn Replace as needed • O-ring on seat is damaged Replace as needed
Leaking out the top of valve	<ul style="list-style-type: none"> • O-rings on piston stem worn or cut Replace as needed
Pressure spikes	<ul style="list-style-type: none"> • Adjusting nut turned completely into regulator • Restricted bypass or no bypass

PARTS LIST

ITEM	P/N	MATL	DESCRIPTION	QTY
403	126521	STCP R	Nut, Adjusting (M8)	3
408	32090	STL	Spring, Pressure (White - 7080)	1
	32092	STL	Spring, Pressure (Blue - 7082)	1
410	—	BB	Retainer, Spring	1
412	33219	S	Stem, Piston	1
414	32873	PTFE	Backup Ring, Stem	1
415	—	NBR	O-Ring, Stem	1
425	33318	BB	Retainer, Piston	1
426	32818	S	Pin, Piston Lock	1
428	—	NBR	O-Ring, Piston Retainer	1
429	—	NBR	O-Ring, Piston	1
430	33303	PTFE	Backup Ring, Piston	2
432	32289	SSSS	Ball	1
434	—	STZP	Spring	1
436	—	NBR	Seat with O-Ring	1
437	—	NBR	O-Ring, Seat	1
440	—	FBB	Body	1
451	—	BB	Plug (3/8" NPT[M])	1
454	—	NBR	O-Ring, Fitting	1
455	32111	BB	Fitting, Inlet (3/8" NPT[F])	1
468	<i>33246</i>	<i>NBR</i>	<i>Kit, O-Ring (Includes: 414, 415, 428, 429, 430, 437, 454)</i>	<i>1</i>
	<i>32878</i>	<i>FPM</i>	<i>Kit, O-Ring (Includes: 414, 415, 428, 429, 430, 437, 454)</i>	<i>1</i>

Italics are optional items.

Bold print part numbers are unique to a particular model

MATERIAL CODES (Not Part of Part Number): BB=Brass FBB=Forged Brass
 FPM=Fluorocarbon NBR=Medium Nitrile (Buna-N)
 PTFE=Pure Polytetrafluoroethylene
 S=304SS STL=Steel SSSS=440SS
 STCP=Steel/Chrome Plated

EXPLODED VIEW

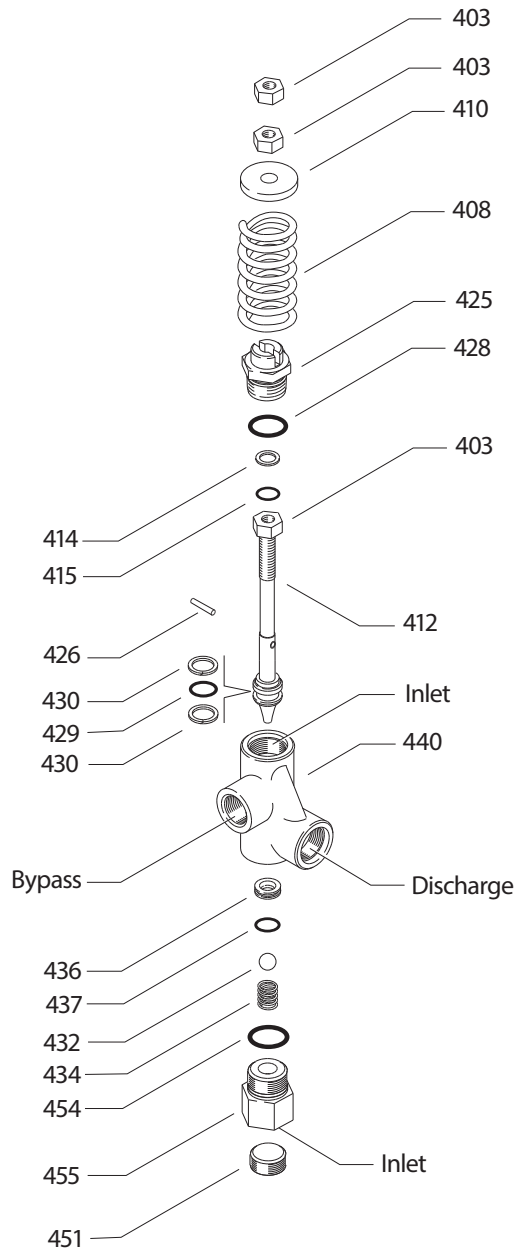

Model Shown 7082

⚠ CAUTIONS AND WARNINGS

All high-pressure systems require a primary pressure regulating device (e.g. regulator, unloader) and a secondary pressure relief device (e.g. pop-off valve, relief valve). Failure to install such relief devices could result in personal injury or damage to pump or property. Cat Pumps does not assume any liability or responsibility for the operation of a customer's high-pressure system. Read all CAUTIONS and WARNINGS before commencing service or operation of any high-pressure system. The CAUTIONS and WARNINGS are included in each Service Manual and with each Accessory Data sheet. CAUTIONS and WARNINGS can also be viewed online at www.catpumps.com/dynamic-literature/cautions-and-warnings or can be requested directly from Cat Pumps.

WARRANTY

View the Limited Warranty online at www.catpumps.com/literature/cat-pumps-limited-warranty