

DATA SHEET

PRESSURE-SENSITIVE REGULATING UNLOADERS



Brass Models: 7537, 7542



Model 7537 Shown

FEATURES

- Provides system pressure control and protection for single or multiple gun applications.
- Maintains full system pressure while running in bypass with minimal load on pump.
- Minimum pressure fluctuations with alternating use of multiple guns.
- Optional handles permits easy adjustment of pressure.
- Color coded spring aids in easy identification and can be quickly transferred from one model to another.
- Unloader comes standard with NBR O-rings. Alternative O-ring materials are available for higher temperatures or chemical compatibility.

SPECIFICATIONS

	U.S.	Metric
7537		
Flow Range	1–21 gpm	3.8–80 lpm
Pressure Range	230–2600 psi	15.8–180 bar
7542		
Flow Range	1–21 gpm	3.8–80 lpm
Pressure Range	800–4000 psi	55–275 bar

COMMON SPECIFICATIONS

	U.S.	Metric
Maximum Temperature (NBR)	140° F	60° C
Inlet Ports (2)	½" NPT(F)	½" NPT(F)
Discharge Port	½" NPT(F)	½" NPT(F)
Bypass Port	½" NPT(F)	½" NPT(F)
Weight	2.54 lbs	1.15 kg
Dimensions	7.57 x 3.96 x 1.74"	192 x 100 x 44.3mm

Use only at above specifications to ensure proper unloader life and performance.

 This Pressure-Sensitive Regulating Unloader can be converted to a Secondary Relief Valve. See page 4 for Relief Valve conversion.

ALTERNATIVE O-RING CONFIGURATION

MATERIAL	SUFFIX CODE	MAXIMUM TEMPERATURE	
NBR	—	140° F	(60° C)
FPM	.0110	240° F	(115° C)

Read all CAUTIONS and WARNINGS before commencing service or operation of any high-pressure system

SELECTION

These pressure-sensitive regulating unloaders are designed for systems with single or multiple pumps, solenoid (gate) valves, nozzles, standard or weep guns.

Note: For multiple-pump systems, it is best to use a pressure regulator, not a pressure-sensitive regulating unloader.

These unloaders should meet both the desired system flow (combined nozzle flow rate requirement) and the desired system pressure.

Note: Operation below the minimum rated flow of the unloader causes the unloader to cycle. Operation above the maximum rated flow of the unloader causes cycling and premature wear, preventing achievement of the desired system pressure.

INSTALLATION

These unloaders operate properly when mounted in any direction. However, keeping the plumbing to a minimum and the hex adjusting nut easily accessible is preferred. The preferred mounting location is directly on the pump's discharge manifold.

There are two (2) inlet connections on these unloaders. Both are 1/2" NPT(F) ports and are located on the short extension side and bottom. An arrow and the word IN are cast into the body indicating the direction of flow. Liquid from the discharge of the pump goes into this connection.

The discharge connection is a 1/2" NPT(F) port. An arrow and the word OUT are cast into the body indicating the direction of flow. Plumbing to the spray guns, solenoid (gate) valves or nozzles connect here.

The bypass connection is a 1/2" NPT(F) port located on the side of the body. The word BY-PASS is cast into the body. Bypass liquid is directed out of this port and can be routed to a reservoir (preferred method), drain or pump inlet.

OPERATION

These pressure-sensitive regulating unloaders hold established system pressure in the discharge line when the trigger gun or solenoid (gate) valve is closed, or the nozzle is clogged, thus bypassing all unrequired flow. Squeezing the trigger gun or opening the solenoid (gate) valve will close the bypass and return to established system pressure.

PRESSURE ADJUSTMENT

Note: Pressure is not set at the factory.

1. Setting and adjusting the unloader pressure must be done while the system is running.
 2. Start the system with unloader backed off to the lowest pressure setting (counterclockwise direction).
 3. Increase the unloader pressure setting by turning the hex adjusting nut or handle clockwise..
 4. Squeeze the trigger and read the pressure on the gauge at the pump.
- Note:** Do not read the pressure at the gun or nozzle.
5. If more pressure is desired, release the trigger, turn hex adjusting nut or handle one quarter turn in clockwise direction.
 6. Squeeze the trigger and read the pressure.
 7. Repeat this process until desired system pressure is reached.

Notice: A minimum of 5% of the flow through the unloader should bypass for proper unloader performance. If the entire unloader flow pumps through the nozzle (zero-bypass), the valve can easily be set for pressure higher than the desired pressure, causing a malfunction or premature wear.

8. If desired system pressure cannot be reached, review TROUBLESHOOTING chart.

Note: A secondary pressure safety relief device (e.g. pop-off valve, relief valve) should be used along with these pressure-sensitive regulating unloaders. Final adjustment for the relief valve should relieve at 200 psi above the system operating pressure.

Note: By removing the check valve and spring, these unloaders can function as a secondary relief valve.

🔧 See page 4 for Relief Valve conversion.

TYPICAL UNLOADER INSTALLATION

1. Pressure Gauge
2. Relief Valve (Secondary Pressure Relief Device)
3. Pulsation Dampener
4. Pressure Sensitive Regulating Unloader (Primary Pressure Regulating Device)
5. Triplex Plunger Pump

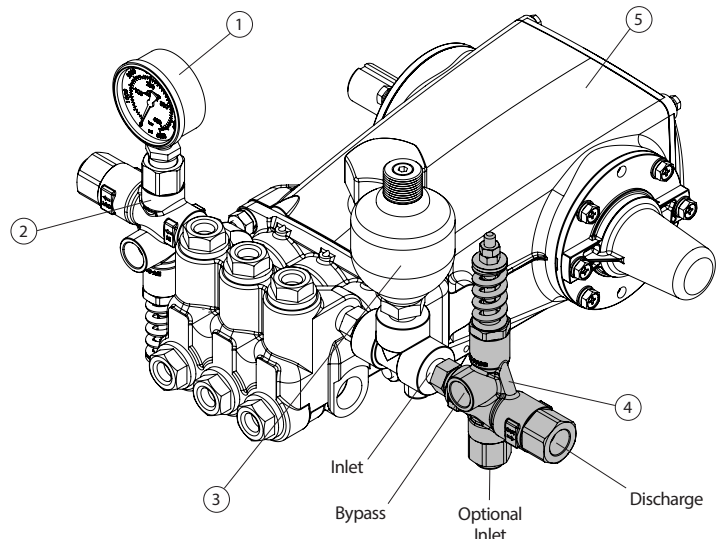

Read all CAUTIONS and WARNINGS before commencing service or operation of any high-pressure system

SERVICING

Disassembly

1. Disconnect bypass, discharge and inlet plumbing from unloader.
2. Remove unloader from pump.
3. Secure body of unloader in a vise with hex adjusting nuts or handle facing up.
4. Remove discharge fitting and O-ring, spring and check valve with O-ring.
5. Examine check valve and discharge fitting for wear, spring for wear or fatigue, and O-rings for cuts or wear. Replace as needed.

Note: While the discharge fitting is removed, inspect sealing area where the check valve makes contact within the internal body of the unloader for grooves, pitting and wear. If damage is found, stop the repair and replace with complete new unloader. If not, proceed with disassembly.

6. Remove two (2) hex adjusting nuts by turning in a counterclockwise direction.
7. Remove spring retainer and spring.
8. Examine spring and spring retainer for scale build up, fatigue or wear. Replace as needed.
9. Use wrench to unthread and remove piston retainer and piston stem together from main unloader body.
10. Examine piston stem and piston retainer for scale build up, scoring, pitting and wear. Replace as needed. Examine O-rings and backup rings for cuts or wear. Replace as needed.
11. Remove unloader body from vise and reposition in vise with bottom inlet port facing up.
12. Remove inlet fitting with O-ring, spring and ball.
13. Remove unloader body from vise and reposition in vise with bottom inlet port facing down.
14. Drive out seat and O-ring from the top side.
15. Examine seat, spring and ball for scale build up, scoring and wear. Replace as needed. Examine O-rings for cuts or wear. Replace as needed.

Reassembly

1. Remove unloader body from vise and reposition in vise with bottom inlet port facing up.
2. Lubricate and install O-ring onto outside diameter of seat.
3. Place seat with O-ring into unloader body with small inside diameter hole facing up.
4. Place ball onto seat and then spring.
5. Lubricate and install O-ring onto inlet fitting. Thread in inlet fitting by hand and tighten.
6. Remove unloader body from vise and reposition in vise with bottom inlet fitting facing down.
7. Lubricate and install O-ring and then backup ring over threaded end of piston stem small diameter groove.
8. Install backup ring, O-ring and then backup ring on opposite end of threaded piston stem. Lubricate all parts.
9. Lubricate and install O-ring onto piston retainer.
10. Place threaded end of piston retainer over the threaded end of the piston stem.
11. Place piston retainer and piston stem assembly into unloader body with threaded end of piston stem facing up. Thread piston retainer into unloader body by hand and tighten with wrench.
12. Apply Loctite® 242® to the bottom threads of the piston stem.
13. Hand thread one (1) hex nut onto piston stem and tighten with wrench.
14. Place spring over piston stem and then spring retainer onto spring with stepped surface facing down.
15. Hand thread two (2) hex nuts onto piston stem.
16. Lubricate O-ring on check valve. Insert check valve with O-ring facing into unloader body. Place spring onto check valve.
17. Lubricate O-ring on discharge fitting. Hand thread into unloader body and tighten with wrench.
18. Remove unloader from vise.
19. Re-install unloader onto pump.
20. Reconnect bypass, discharge and inlet plumbing to unloader.
21. Proceed to PRESSURE ADJUSTMENT.

Loctite and 242 are registered trademarks of the Henkel Corporation.

TROUBLESHOOTING

Unloader cycles	<ul style="list-style-type: none"> • Worn O-ring or check valve • Fitting leaking downstream • O-ring in gun is worn
Liquid leaking from bottom	<ul style="list-style-type: none"> • O-ring for seat or inlet fitting is cut or worn
Liquid leaking from middle	<ul style="list-style-type: none"> • Piston O-ring is cut or torn
Unloader will not come up to pressure	<ul style="list-style-type: none"> • Not properly sized for system pressure • Foreign material in unloader • Piston O-rings are worn • Nozzle worn or sized incorrectly • Jam nuts not properly set
Extreme pressure spikes	<ul style="list-style-type: none"> • Adjusting handle turned completely into unloader • Restricted bypass or no bypass • System flow exceeds unloader rating

PARTS LIST

ITEM	PN	MATL	PN	MATL	DESCRIPTION	QTY
	7537		7542			
402	31766	NY	31766	NY	Handle, Adjustment	1
403	126521	STCP R	126521	STCP R	Nut, Hex Adjusting (M8)	2
408	32090	STL	—	—	Spring Pressure (White)	1
	—	—	32092	STL	Spring Pressure (Blue)	1
409	—	BB	—	BB	Nut, Hex (M8)	1
410	32115	BB	32115	BB	Retainer, Spring	1
412	76170	S	76170	S	Stem, Piston	1
414	—	PTFE	—	PTFE	Backup Ring, Piston Stem	1
415	—	NBR	—	NBR	O-Ring, Piston Stem	1
425	76727	BB	76727	BB	Retainer, Piston	1
428	—	NBR	—	NBR	O-Ring, Piston Retainer	1
429	—	NBR	—	NBR	O-Ring, Piston Stem	1
430	—	PTFE	—	PTFE	Backup Ring, Piston Stem	2
434	76022	S	76022	S	Spring, Seat	1
435	76706	SS	76706	SS	Ball and Seat Assembly (2-Piece)	1
437	—	NBR	—	NBR	O-Ring, Seat	1
439	—	NBR	—	NBR	O-Ring, Inlet Fitting	1
440	—	FBB	—	FBB	Body	1
441	—	NBR	—	NBR	O-Ring, Check Valve	1
443	76745	BB	76745	BB	Valve, Check with NBR O-Ring	1
	76723	BB	76723	BB	Valve, Check with FPM O-Ring	1
444	76722	S	76722	S	Spring, Check Valve	1
446	—	NBR	—	NBR	O-Ring, Discharge Fitting	1
455	76018	BB	76018	BB	Fitting, Inlet (1/2" NPT[F])	1
460	76024	BB	76024	BB	Fitting, Discharge (1/2" NPT[F])	1
462	30533	BB	30533	BB	Plug, Inlet (1/2" NPT[M])	1
468	76671	NBR	76671	NBR	Kit, O-Ring (Includes: 414, 415, 428, 429, 430, 437, 439, 441, 446) After Week #41, 2016 (7537); Week #29, 2016 (7542)	1
—	76680	FPM	76680	FPM	Kit, O-Ring (Includes: 414, 415, 428, 429, 430, 437, 439, 441, 446) After Week #41, 2016 (7537); Week #29, 2016 (7542)	1

*See **Tech Bulletin 120** for changes prior to Week #41/2016 and Week #29/2016.

Bold print part numbers are unique to a particular model.

Italics are optional items.

R Components comply with RoHS Directive. MATERIAL CODES (Not Part of Part Number): BB=Brass FBB=Forged Brass FPM=Fluorocarbon
NBR=Medium Nitrile (Buna-N) PTFE=Pure Polytetrafluoroethylene S=304SS
SS=316SS STCP=Steel/Chrome Plated STL=Steel

EXPLODED VIEW

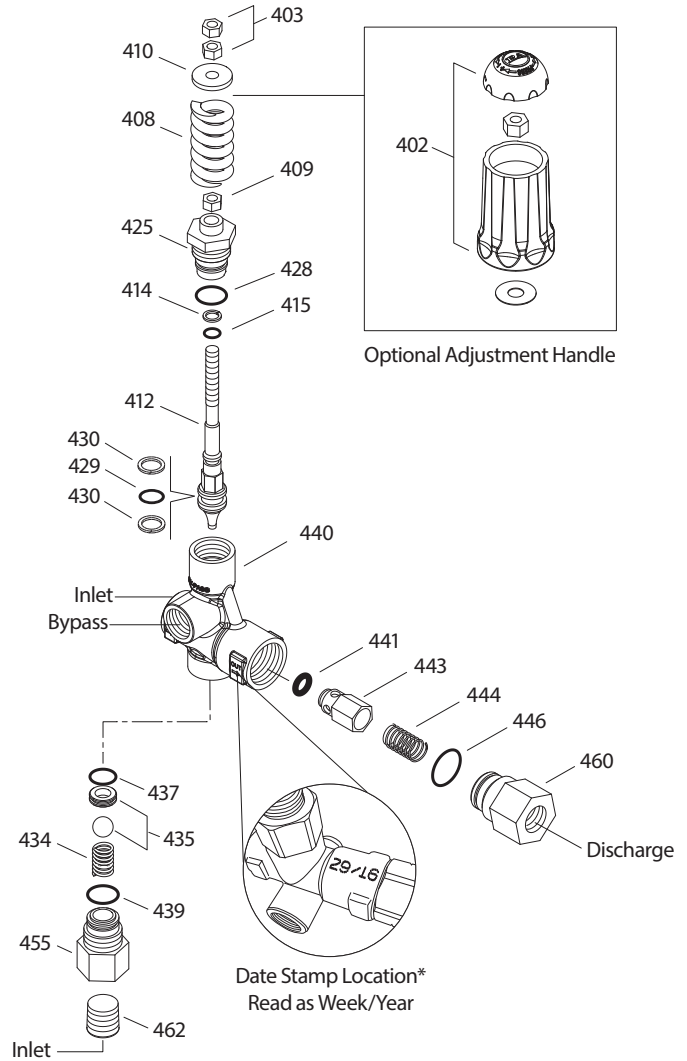

To convert to optional handle assembly, remove items 403 (quantity 2), 410 and 409. Then reassemble as shown in insert.

REGULATING UNLOADER TO RELIEF VALVE CONVERSION

The 7537 and 7542 Pressure-Sensitive Regulating Unloaders are typically used as a primary pressure regulating device. They can be converted to a Relief Valve to be used as a secondary pressure relief device by removing the discharge check valve, O-ring, and spring.

Unloader PN	Modifications	Converted Relief Valve PN	
7537	Remove parts 441, 443, 444	7537.100 (NBR Seals)	7537.1110 (FPM Seals)
7542		7542.100 (NBR Seals)	7537.1110 (FPM Seals)

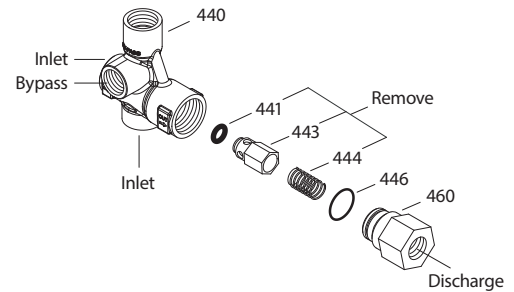

CAUTIONS AND WARNINGS

All high-pressure systems require a primary pressure regulating device (e.g. regulator, unloader) and a secondary pressure relief device (e.g. pop-off valve, relief valve). Failure to install such relief devices could result in personal injury or damage to pump or property. Cat Pumps does not assume any liability or responsibility for the operation of a customer's high-pressure system. Read all CAUTIONS and WARNINGS before commencing service or operation of any high-pressure system. The CAUTIONS and WARNINGS are included in each Service Manual and with each Accessory Data sheet. CAUTIONS and WARNINGS can also be viewed online at www.catpumps.com/dynamic-literature/cautions-and-warnings or can be requested directly from Cat Pumps.

WARRANTY

View the Limited Warranty online at www.catpumps.com/literature/cat-pumps-limited-warranty