

DATA SHEET

PRESSURE-SENSITIVE REGULATING UNLOADERS



Brass Models: 7693, 7694



Model 7693 Shown

FEATURES

- Provides system pressure control and protection for single gun (non-weep) applications.
- Maintains full system pressure while running in bypass with minimal load on pump.
- Compact size allows for easy installation.
- Color-coded spring aids in easy identification and can be quickly transferred from one model to another.
- Unloader comes standard with NBR O-rings. Alternative O-ring materials are available for higher temperatures or chemical compatibility.

SPECIFICATIONS

U.S. Measure

Metric Measure

7693

Flow Range	2.5–10.5 gpm	9.5–40 lpm
Pressure Range	230–2300 psi	16–160 bar
Weight	1.56 lbs	0.71 kg

7694

Flow Range	2.5–10.5 gpm	9.5–40 lpm
Pressure Range	400–4050 psi	28–280 bar
Weight	1.63 lbs	0.74 kg

Use only at above specifications to ensure proper unloader life performance.

COMMON SPECIFICATIONS

U.S.

Metric

Maximum Temperature (NBR)	140° F	60° C
Inlet Ports (2)	3/8" NPT(F)	3/8" NPT(F)
Discharge Port	3/8" NPT(F)	3/8" NPT(F)
Bypass Ports (2)	3/8" NPT(F)	3/8" NPT(F)
Dimensions	7.51 x 3.25 x 1.97"	190 x 82 x 50mm

Use only at above specifications to ensure proper unloader life performance.

 This Pressure-Sensitive Regulating Unloader can be converted to a Secondary Relief Valve. See page 4 for Relief Valve conversion.

ALTERNATIVE O-RING CONFIGURATION

MATERIAL	SUFFIX CODE	MAXIMUM TEMPERATURE	
NBR	—	140° F	(60° C)
FPM	.0110	240° F	(115° C)

Read all CAUTIONS and WARNINGS before commencing service or operation of any high-pressure system

SELECTION

These pressure-sensitive regulating unloaders are designed for systems with single pumps, solenoid (gate) valves and nozzles. Weep guns are not recommended with these unloaders.

Note: For multiple-pump systems, it is best to use a pressure regulator, not a pressure-sensitive regulating unloader.

These unloaders should meet both the desired system flow (combined nozzle flow rate requirement) and the desired system pressure.

Notice: Operation below the minimum rated flow of the unloader causes the unloader to cycle. Operation above the maximum rated flow of the unloader causes cycling and premature wear, preventing achievement of the desired system pressure.

INSTALLATION

These unloaders will operate properly when mounted in any direction. However, keeping the plumbing to a minimum and the hex adjusting nut easily accessible is preferred. The preferred mounting location is directly on the pump's discharge manifold.

There are two (2) inlet connections on these unloaders. Both are $\frac{3}{8}$ " NPT(F) ports and are located on the short extension side and bottom. An arrow and the word IN are cast into the body indicating the direction of flow. Liquid from the discharge of the pump goes into this connection.

The discharge connection is a $\frac{3}{8}$ " NPT(F) port. An arrow and the word OUT are cast into the body indicating the direction of flow. Plumbing to the spray guns, solenoid (gate) valves or nozzles connect here.

The bypass connections $\frac{3}{8}$ " NPT(F) ports located on the side of the body. The word BY-PASS is cast into the body. Bypass liquid is directed out of either of these ports and can be routed to a reservoir (preferred method), drain or pump inlet.

OPERATION

These pressure-sensitive regulating unloaders hold the established system pressure in the discharge line when the trigger gun or solenoid (gate) valve is closed or the nozzle is clogged, thus bypassing all unrequired flow. Squeezing the trigger gun or opening the solenoid (gate) valve will close the bypass and return to established system pressure.

PRESSURE ADJUSTMENT

Note: Pressure is not set at the factory.

1. Setting and adjusting the unloader pressure must be done while the system is running.
 2. Start the system with unloader backed off to the lowest pressure setting (counterclockwise direction).
 3. Increase the unloader pressure setting by turning the hex adjusting nut or handle clockwise.
 4. Squeeze the trigger and read the pressure on the gauge at the pump.
- Note:** Do not read the pressure at the gun or nozzle.
5. If more pressure is desired, release the trigger, turn hex adjusting nut or handle one quarter turn in clockwise direction.
 6. Squeeze the trigger and read the pressure.
 7. Repeat this process until desired system pressure is reached.

Notice: A minimum of 5% of the flow through the unloader should bypass for proper unloader performance. If the entire unloader flow pumps through the nozzle (zero-bypass), the valve can easily be set for pressure higher than the desired pressure, causing a malfunction or premature wear.

8. If desired system pressure cannot be reached, review the TROUBLESHOOTING chart.

Note: A secondary pressure safety relief device (e.g. pop-off valve, relief valve) should be used along with these pressure-sensitive regulating unloaders. Final adjustment for the secondary relief valve should be approximately 200 psi above the system operating pressure.

Note: By removing the check valve and spring, these unloaders can function as a secondary relief valve.

🔧 See page 4 for Relief Valve conversion.

TYPICAL UNLOADER INSTALLATION

1. Pressure Gauge
2. Relief Valve
(Secondary Pressure Relief Device)
3. Pressure-Sensitive Regulating Unloader
(Primary Pressure Regulating Device)
4. Triplex Plunger Pump

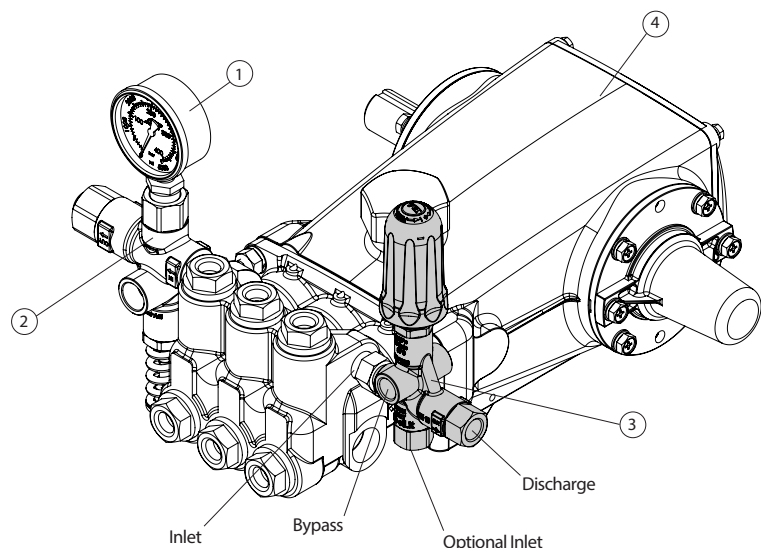

Read all CAUTIONS and WARNINGS before commencing service or operation of any high-pressure system

SERVICING

Disassembly

1. Disconnect bypass, discharge and inlet plumbing from unloader.
2. Remove unloader from pump.
3. Secure body of unloader in a vise with adjusting cap handle facing up.
4. Remove discharge fitting and O-ring, spring, check valve and O-ring.
5. Examine check valve and discharge fitting for wear, spring for wear or fatigue and O-rings for cuts or wear. Replace as needed with new check valve kit.

Note: While the discharge fitting is removed, inspect sealing area where the check valve makes contact within the internal body of the unloader for grooves, pitting and wear. If damage is found, stop the repair and replace with complete new unloader. If not, proceed with disassembly.

6. Remove black cap handle.
7. Remove hex nylock nut.
8. Unscrew and remove adjusting handle, flat washer and spring.
9. Examine all parts for scale build up or wear. Replace as needed. Examine spring for fatigue or wear. Replace as needed.
10. Unscrew and remove two jam nuts from piston stem.
11. Unscrew piston retainer from body of unloader.
12. Grasp threaded end of piston stem and pull from body of unloader. Piston retainer and all associated backup rings and O-rings should come out upon removal.
13. Remove piston retainer, O-rings and backup rings. Examine piston retainer for wear. Examine O-rings and backup rings for cuts or wear. Replace as needed.
14. Examine piston stem for wear. Examine O-ring and backup rings for cuts or wear. Replace as needed.
15. Remove bottom inlet fitting with O-ring, spring, ball and seat with O-ring from bottom inlet connection. Examine seat for grooves and O-ring for cuts or wear. Replace as needed.

Reassembly

1. Lubricate and install O-ring onto inlet fitting.
2. Place inlet fitting with threads facing up on a flat surface.
3. Place spring and ball onto inlet fitting.
4. Lubricate and install O-ring onto seat.
5. Place seat with O-ring onto ball with chamfered surface facing the ball.
6. Carefully hand thread inlet fitting and components into unloader body.
7. Lubricate and install O-ring and then backup ring onto threaded end of the piston stem.
8. Lubricate and install backup ring, O-ring and then backup ring on the opposite end of the threaded piston stem.
9. Grasp threaded end of piston stem and press by hand into unloader body.
10. Lubricate and install larger O-ring over threads of piston retainer body. Slide piston retainer with threads facing downwards over piston stem and thread into body.
11. Apply Loctite® 242® to the last few threads of the piston stem. Hand thread two jam nuts to the bottom threads of piston stem.
12. Slide spring over piston stem. Install flat washer on top of the spring.
13. Thread adjusting handle onto piston stem.
14. Install hex nylock onto piston stem.
15. At discharge side of unloader, lubricate and install O-ring onto check valve. Place spring inside check valve. Insert check valve with O-ring and spring into discharge port of unloader body.
16. Lubricate and install O-ring onto threaded end of discharge fitting. Thread in discharge fitting to discharge port of unloader body and tighten with a wrench.
17. Re-install black cap handle by snapping in place.
18. Remove unloader from vise.
19. Re-install unloader onto pump.
20. Reconnect bypass, discharge and inlet plumbing to unloader.
21. Proceed to PRESSURE ADJUSTMENT.

Loctite and 242 are registered trademarks of the Henkel Corporation.

TROUBLESHOOTING

Unloader cycles	<ul style="list-style-type: none"> • Worn O-ring or check valve • Fitting leaking downstream • O-ring in gun is worn
Liquid leaking from bottom	<ul style="list-style-type: none"> • O-ring for seat or inlet fitting is cut or worn
Liquid leaking from middle	<ul style="list-style-type: none"> • Piston O-ring is cut or worn
Unloader will not come up to pressure	<ul style="list-style-type: none"> • Not properly sized for system pressure • Foreign material in unloader • Piston stem O-rings are worn • Nozzle worn or sized incorrectly • Jam nuts not properly set
Extreme pressure spikes	<ul style="list-style-type: none"> • Adjusting handle turned completely into unloader • Restricted bypass or no bypass • System flow exceeds unloader rating

PARTS LIST

ITEM	PN	MATL	DESCRIPTION	QTY
397	33633	STZP	Washer, Flat	1
398	32116	BB	Nut, Jam (M8 x 1.25)	2
401	—	STZP	Nut, Hex Lock	1
403	31766	NY	Handle, Cap	1
408	32090	STL	Spring, Pressure (White) Model 7693	1
	32092	STL	Spring, Pressure (Blue) Model 7694	1
412	39727	S	Stem, Piston	1
414	—	PTFE	Backup Ring, Piston Stem	1
415	—	NBR	O-Ring, Piston Stem	1
425	—	S	Retainer, Piston	1
428	—	NBR	O-Ring, Piston Retainer	1
429	—	NBR	O-Ring, Piston Stem	1
430	—	PTFE	Backup Ring, Piston Stem	2
434	32325	S	Spring	1
436	76743	—	Seat, Ball Assembly	1
440	—	BB	Housing	1
441	—	NBR	O-Ring, Check Valve	1
442	—	NBR	O-Ring, Bypass Fitting	1
443	76736	BB	Valve, Check with O-Ring	1
444	33843	S	Spring, Check Valve	1
446	—	NBR	O-Ring, Discharge Fitting	1
455	76752	BB	Fitting, Inlet (3/8" NPT[F])	1
460	76753	BB	Fitting, Discharge (3/8" NPT[F])	1
462	—	BB	Plug, Inlet (3/8" NPT[M])	2
468	76787*	<i>NBR</i>	<i>Kit, O-Ring (Includes: 414, 415, 428-430, 441, 442, 446) After Week #4, 2015 (7693); Week #12, 2015 (7694)</i>	<i>1</i>
	76760*	<i>FPM</i>	<i>Kit, O-Ring (Includes: 414, 415, 428-430, 441, 442, 446) After Week #4, 2015 (7693); Week #12, 2015 (7694)</i>	<i>1</i>
470	39697*	<i>NBR</i>	<i>Kit, Repair (Includes: 414, 415, 428-430, 436, 441, 442, 446) After Week 4/2015 (7693); Week #12, 2015 (7694)</i>	<i>1</i>

*See Tech Bulletin #119 for changes prior to week 4/2015 and week 12/2015.

Italics are optional items.

Bold print part numbers are unique to a particular model.

MATERIAL CODES (Not Part of Part Number): BB=Brass FPM=Fluorocarbon
 NBR=Medium Nitrile (Buna-N) NY=Nylon PTFE=Pure Polytetrafluoroethylene
 S=304SS STL=Steel STZP=Steel/Zinc Plated

EXPLODED VIEW

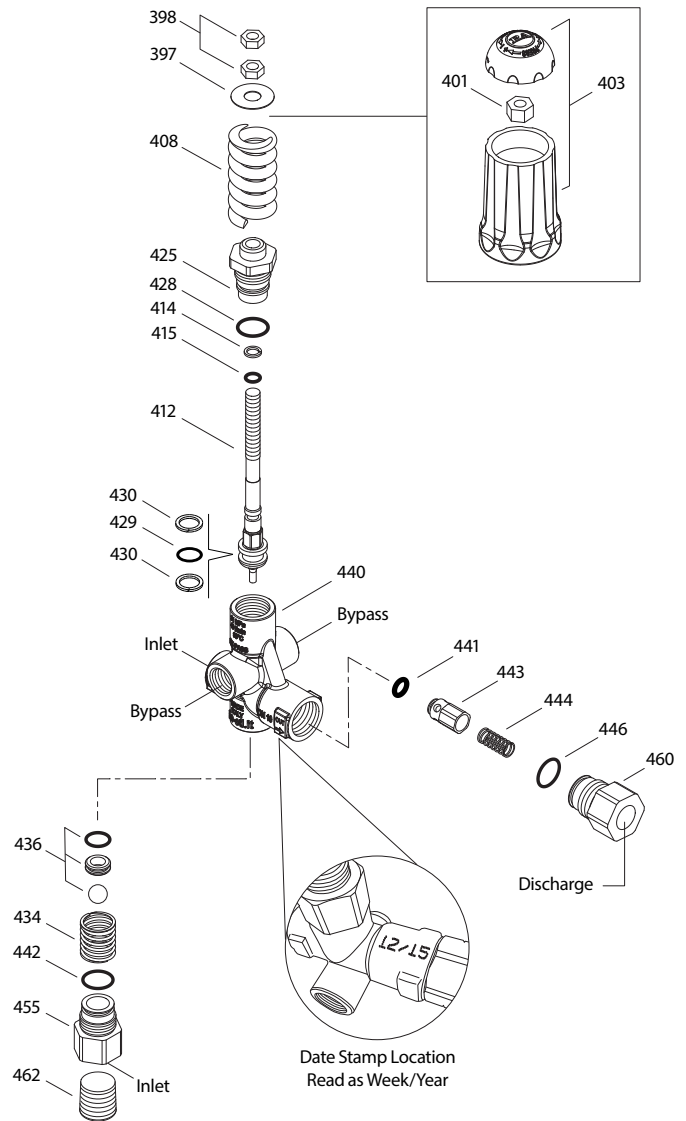

REGULATING UNLOADER TO RELIEF VALVE CONVERSION

The 7693 and 7694 Pressure-Sensitive Regulating Unloaders are typically used as a primary pressure regulating device. They can be converted to a Relief Valve to be used as a secondary pressure relief device by removing the discharge check valve with O-ring, and spring.

Unloader PN	Modifications	Converted Relief Valve PN	
7693	Remove parts 441, 443, 444	7693.100 (NBR Seals)	7693.1110 (FPM Seals)
7694		7694.100 (NBR Seals)	7694.1110 (FPM Seals)

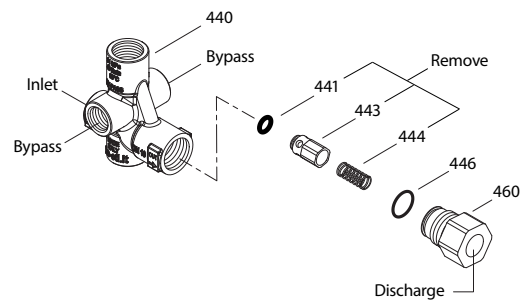

CAUTIONS AND WARNINGS

All high-pressure systems require a primary pressure regulating device (e.g. regulator, unloader) and a secondary pressure relief device (e.g. pop-off valve, relief valve). Failure to install such relief devices could result in personal injury or damage to pump or property. Cat Pumps does not assume any liability or responsibility for the operation of a customer's high-pressure system. Read all CAUTIONS and WARNINGS before commencing service or operation of any high-pressure system. The CAUTIONS and WARNINGS are included in each Service Manual and with each Accessory Data sheet. CAUTIONS and WARNINGS can also be viewed online at www.catpumps.com/dynamic-literature/cautions-and-warnings or can be requested directly from Cat Pumps.

WARRANTY

View the Limited Warranty online at www.catpumps.com/literature/cat-pumps-limited-warranty