

DATA SHEET

PRESSURE REGULATOR



Stainless Steel **7350**
Model:



SPECIFICATIONS	U.S.	Metric
Flow Range	1–12 gpm	3.78–45.4 lpm
Pressure Range	400–1500 psi	27.5–103 bar
Maximum Temperature	180° F	82° C
Inlet Port	¼" NPT(F)	¼" NPT(F)
Bypass Port	⅜" NPT(F)	⅜" NPT(F)
Weight	1.42 lbs	0.64 kg
Dimensions	2.26 x 6"	56 x 152 mm

FEATURES

- Maintains full pressure while running in idle for quick return to system pressure.
- Stainless steel conical piston and seat extend valve life by providing a consistently smooth flow that reduces wear and compensates for pressure spikes.
- Minimum pressure fluctuations with the alternating use of multiple guns and nozzles.
- Top adjusting cup and locking nut secure calibrated pressure setting.
- Stainless steel internal parts results in durability and compatibility.
- Standard FPM elastomers promote compatibility with many liquids.

Read all CAUTIONS and WARNINGS before commencing service or operation of any high-pressure system

SELECTION

This pressure regulator is designed for systems with single or multiple pumps, solenoid (gate) valves, nozzles, shut-off or weep guns.

Note: For multiple-pump systems, it is best to use a pressure regulator, not a pressure-sensitive regulating unloader.

This regulator should meet both the desired system flow (combined nozzle flow rate) and the desired system pressure.

NOTICE: Operating below the minimum rated flow of the regulator will cause the regulator to cycle or chatter. Operating above the maximum rated flow of the regulator will cause premature regulator wear, regulator cycling and wear, preventing the desired system pressure.

INSTALLATION

This regulator will operate when mounted in any direction. However, keeping the plumbing to a minimum and the adjusting cap easily accessible is preferred. The preferred mounting location is directly to the pump discharge manifold or perpendicular to the discharge line.

The inlet connection is a 1/4" NPT(F) port located on the side.

The bypass connection is a 3/8" NPT(F) port located on the bottom of the valve body. Bypass liquid is directed out of this port and can be routed to a reservoir (preferred method), drain or pump inlet.

OPERATION

This pressure regulator maintains system pressure in the discharge line and at the pump head when the trigger gun or the solenoid (gate) valve is closed, or the nozzles are clogged, thus bypassing all unrequired flow. Squeezing the trigger gun or opening the solenoid valve allows for a quick return to system pressure.

PRESSURE ADJUSTMENT

Note: Pressure is not set at the factory.

1. Setting and adjusting the regulator pressure must be done while system is running.
2. Start the system with the regulator backed off to the lowest pressure setting (counterclockwise).
3. Increase the regulator pressure setting by turning the adjustment cap clockwise.
4. Squeeze the trigger and read the pressure on the gauge at the pump.

Note: Do not read the pressure at the gun or nozzle.

5. If more pressure is desired, release the trigger, turn the adjusting cap one-quarter turn in a clockwise direction.
6. Squeeze the trigger and reread the pressure.
7. Once the desired system pressure is reached, stop turning the adjusting cap and thread the jam nut down towards the upper body of the regulator to lock it in place.

NOTICE: A minimum of 5% of the flow through the regulator should bypass for proper regulator performance. If the entire regulator flow pumps through the nozzle (zero bypass), the valve can easily be set for pressure higher than the desired pressure, causing a malfunction or premature wear.

8. If desired system pressure cannot be reached, review TROUBLESHOOTING chart.

Note: Do not adjust regulator pressure setting to compensate for a worn nozzle. Check the nozzle as part of the regular maintenance and replace if worn.

Note: A secondary pressure safety relief device (e.g., pop-off valve or safety valve) should be used along with this pressure regulator. Final adjustment of the relief valve should relieve at 200 psi above the system operating pressure.

TYPICAL REGULATOR INSTALLATION

1. Pressure Gauge
2. Relief Valve (Secondary Pressure Relief Device)
3. Pulsation Dampener
4. **Pressure Regulator (Primary Pressure Regulating Device)**
5. Triplex Plunger Pump

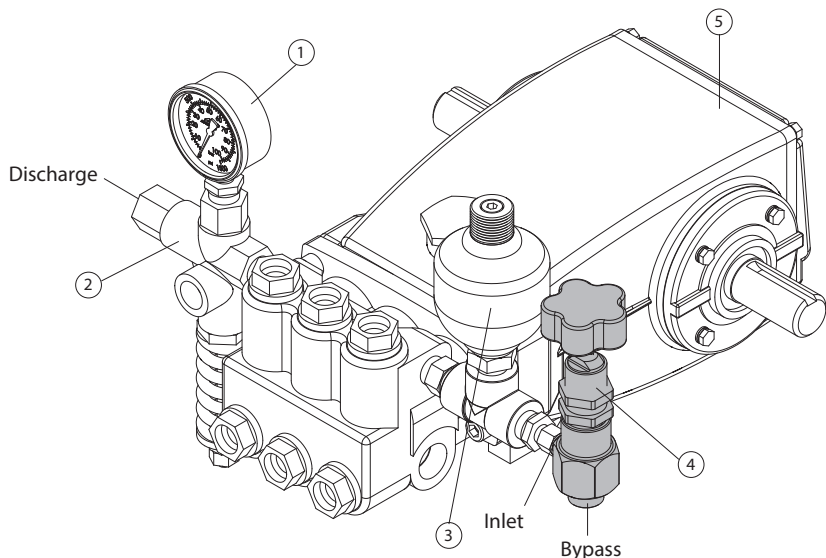

Read all CAUTIONS and WARNINGS before commencing service or operation of any high-pressure system

SERVICING

Disassembly

1. Disconnect bypass and inlet plumbing from the regulator.
2. Remove regulator from the pump.
3. Secure lower body of regulator in a vise with adjusting handle facing upwards.
4. Remove adjusting cap by unthreading from the upper body in a counterclockwise direction.
5. Remove upper body by unthreading from the lower body.
6. Remove spring retainer, spring set and conical piston.

NOTICE: Exercise extreme caution to avoid contact that could damage the outside diameter and sharp tip of the conical piston.

7. Remove the lower body from the vise and place it on a flat surface with the bypass port facing upwards.
8. Using a tool with the same diameter as the conical seat, drive out the conical seat and piston retainer.

NOTICE: Exercise extreme caution to avoid contact and damage to the inside diameter of the piston retainer, as well as the outside diameter and tapered surfaces of the conical seat.

Note: With the regulator completely disassembled, inspect the sealing area where the conical seat and piston retainer make contact within the regulator's lower body for grooves, pitting and wear. If damage is found, stop the repair and replace the lower body. If damage is more severe, installation of a new regulator is suggested. If no damage is found, proceed with the reassembly.

Reassembly

1. Place lower regulator body with bypass port facing downwards in a vise.
2. Lubricate and install the O-ring onto the outside diameter of the conical seat. Press the conical seat down into the lower regulator body with the tapered surface facing upwards.
3. Lubricate and install O-ring onto piston retainer. Press piston retainer with the larger diameter facing downwards.
4. Place conical piston on a flat surface with the sharp point facing upwards. Lubricate and install backup ring, then O-ring onto the outside diameter of the conical piston. Lubricate outside diameter of conical piston.
5. Press conical piston with the sharp point down into piston retainer.
6. Place the upper body with the large opening facing up.
7. Drop spring retainer into the cap, ensuring spring pilot faces up.
8. Drop in 28 spring washers, alternating direction per exploded view on the last page.

Note: Use a small rod such as an ink pen to guide the washers into the cap to ensure the proper orientation is maintained.

9. Invert lower body assembly onto upper body and thread together.
10. Thread adjusting cap into the upper body.
11. Re-install the regulator onto the pump.
12. Reconnect bypass and inlet plumbing to the regulator.
13. Proceed to PRESSURE ADJUSTMENT.

TROUBLESHOOTING

Excessive pressure fluctuations	<ul style="list-style-type: none"> • Too little flow for valve specifications • Air in system, poor connections • Worn low-pressure seals in the pump • Worn O-ring in the gun
System will not build up to pressure	<ul style="list-style-type: none"> • Worn nozzle • Improper nozzle size for system specifications • Foreign material trapped in seat
Pressure drop	<ul style="list-style-type: none"> • Worn nozzle • Worn regulator seat or piston • Air in system, poor connections • Insufficient flow to pump • Filter clogged. Check and clean regularly
Pressure spikes while in bypass	<ul style="list-style-type: none"> • Minimum bypass of 5% not present • Excessive pressure adjustment made for worn nozzle REPLACE NOZZLE. Reset system pressure
Leakage from regulator vent hole	<ul style="list-style-type: none"> • Piston retainer scored, or worn O-ring Service with O-ring kit

PARTS LIST

ITEM	P/N	MATL	DESCRIPTION	QTY
401	30161	—	Cap, Adjusting, Assembly (Includes: Cap, Stud, Jam Nut)	1
406	—	STNP	Body, Upper	1
408	76229	STL	Spring Set	1
410	30726	BB	Retainer, Spring	1
418	30566	SSB	Piston, Conical	1
427	31488	SS	Retainer, Piston	1
436	76724	SSB	Seat, Conical	1
440	—	SS	Body, Lower	1
468	30749	FPM	Kit, O-Ring	1
490	34090	STL	Panel Mount Assembly (Includes: 2 Jam Nuts)	1

Italics are optional items.

Material Codes (Not Part of Part Number): BB=Brass FPM=Fluorocarbon
SS=316SS SSB=316SS Condition B STL=Steel STNP=Steel Nickel Plated

EXPLODED VIEW

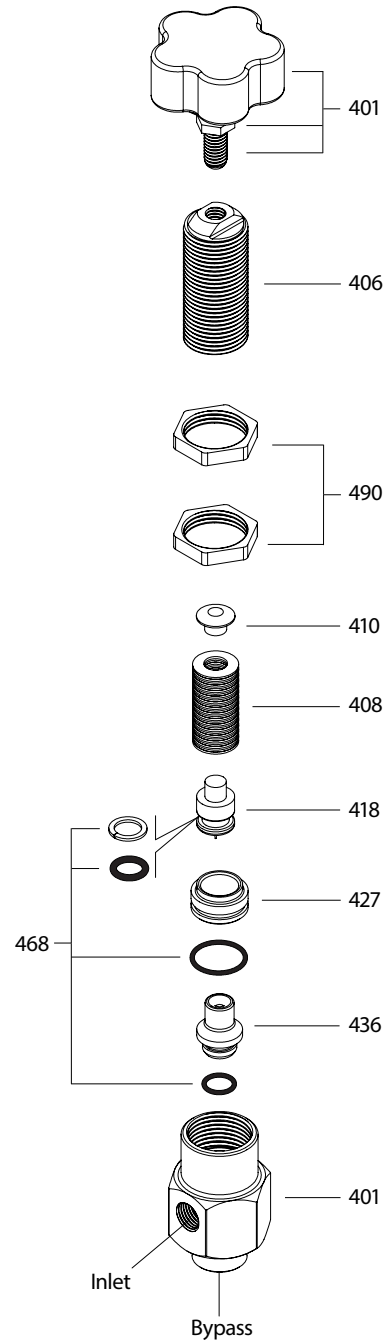

⚠ CAUTIONS AND WARNINGS

All high-pressure systems require a primary pressure regulating device (e.g. regulator, unloader) and a secondary pressure relief device (e.g. pop-off valve, relief valve). Failure to install such relief devices could result in personal injury or damage to pump or property. Cat Pumps does not assume any liability or responsibility for the operation of a customer's high-pressure system. Read all CAUTIONS and WARNINGS before commencing service or operation of any high-pressure system. The CAUTIONS and WARNINGS are included in each Service Manual and with each Accessory Data sheet. CAUTIONS and WARNINGS can also be viewed online at www.catpumps.com/dynamic-literature/cautions-and-warnings or can be requested directly from Cat Pumps.

WARRANTY

View the Limited Warranty online at www.catpumps.com/literature/cat-pumps-limited-warranty