

DATA SHEET

35 FRAME PLUNGER PUMP

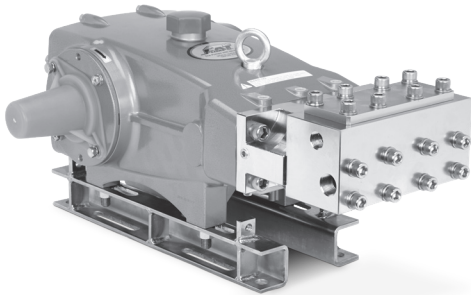

Brass Model: 3550



Model 3550 Shown
(Shaft protector included; mounting rails sold separately)

FEATURES

- Triplex plunger design ensures high efficiency and low pulsation.
- V-packings and low-pressure seals are completely lubricated and cooled by pumped liquid, greatly increasing service life.
- Special high-density, polished, concentric plungers provide a true wear surface and extended seal life.
- Wet-end easily serviced without entering crankcase.
- Pump comes standard with NBR seals. Alternative seal materials are available for higher temperature or chemical compatibility.

SPECIFICATIONS	U.S. Measure	Metric Measure
Flow	10 gpm	38 lpm
Pressure Range	100–6000 psi	6.9–414 bar
Pump RPM*	940 rpm	940 rpm
Inlet Pressure Range	Flooded to 70 psi	Flooded to 4.8 bar
Max. Liquid Temp. (NBR)	140° F	60° C
Bore	0.787"	20 mm
Stroke	1.890"	48 mm
Crankcase Capacity	4.2 qts	4 l
Inlets Ports (2)	¾" NPT(F)	¾" NPT(F)
Discharge Ports (2)	½" NPT(F)	½" NPT(F)
Pulley Mounting	Either Side	Either Side
Shaft Diameter	1.378"	35 mm
Weight	124 lbs	56.4 kg
Dimensions	24.17 x 18.11 x 9.76"	614 x 460 x 248 mm

*Pump minimum is 100 RPM.

ALTERNATIVE SEAL CONFIGURATION

MATERIAL	SUFFIX CODE	MAXIMUM TEMPERATURE
NBR	—	140° F (60° C)
HT	.3000	180° F (82° C)

See **Tech Bulletin 002** for inlet conditions and RPM at high-temperature.

$$\text{DETERMINING THE PUMP RPM} \quad \frac{\text{Rated gpm}}{\text{Rated rpm}} = \frac{\text{Desired gpm}}{\text{Desired rpm}}$$

$$\text{DETERMINING THE REQUIRED HP} \quad \frac{\text{hp (Electric Brake)}}{1460} = \frac{\text{gpm x psi}}{1460}$$

$$\text{DETERMINING MOTOR PULLEY SIZE} \quad \frac{\text{Motor Pulley OD}}{\text{Pump rpm}} = \frac{\text{Pump Pulley OD}}{\text{Motor rpm}}$$

Refer to pump **Service Manual** for repair procedure and additional technical information.

PARTS LIST

ITEM	P/N	MATL	DESCRIPTION	QTY
5	96049	S	Screw, HHC, Sems (M10 x 25) (See Tech Bulletins 074, 125)	8
8	134604	ALE	Cover, Bearing (See Tech Bulletins 118, 125)	2
9	815279	FBR	Shim, Split, 2-Piece (See Tech Bulletin 125)	2
10	12398	NBR	O-Ring, Bearing Cover-70D	2
11	13296	NBR	Seal, Oil, Crankshaft	2
15	29326	STL	Bearing, Roller	2
20	121467	TNM	Rod, Connecting Assembly (Includes: 21, 22, 23) (See Tech Bulletin 074)	3
21	126749	STCP R	Washer, Locking (M10)	3
22	126593	STCP R	Washer, Flat (M10)	6
23	122045	STZP	Screw, HH (M10 x 55)	6
25	29325	FCM	Crankshaft, Dual End (M48)	1
31	828710	PE	Protector, Oil Cap with Foam Gasket	1
32	43211	ABS	Cap, Oil Filler	1
33	14177	NBR	O-Ring, Oil Filler Cap-70D	1
34	126743	STCP R	Bolt, Eye (M12 x 1.75) (For Lifting Pump Only)	1
37	92241	PC	Gauge, Oil, Bubble with Gasket	2
38	44428	NBR	Gasket, Flat, Oil Gauge-80D	2
40	125753	S	Screw, HHC, Sems (M8 x 25) (See Tech Bulletin 074)	8
48	25625	STCP	Plug, Drain (1/4" x 19 BSP)	1
49	23170	NBR	O-Ring, Drain Plug-70D	1
50	45936	ALE	Cover, Crankcase (See Tech Bulletin 118)	1
51	16612	NBR	O-Ring, Crankcase-70D	1
53	134786	ALE	Crankcase Assembly (Includes: 54) (See Tech Bulletins 118, 125)	1
54	27488	S	Pin, Guide	2
56	27790	POP	Pan, Oil	1
59	92538	S	Screw, HHC, Sems (M6 x 16)	2
64	43864	CM	Pin, Crosshead	3
65	49076	SHB	Rod, Plunger	3
69	126587	STCP R	Washer, Oil Seal	3
70	100488	NBR S	Seal, Oil, Crankcase	3
75	110669	S	Slinger, Barrier	3
86	132952	D	Adapter	3
88	110670	S	Washer, Keyhole (M16)	3
90	132953	CC	Plunger (M20 x 110)	3
95	126549	STCP R	Stud, Plunger Retainer (M7 x 103)	3
96	132954	PTFB	Backup Ring, Plunger Retainer	3
97	14190	NBR	O-Ring, Plunger Retainer-70D	3
98	44069	SS	Gasket, Retainer	3
99	44068	SS	Retainer, Plunger (M7) (See Tech Bulletin 074)	3
100	44119	PPG	Retainer, Seal (See Tech Bulletin 105)	3
101	44095	—	Wick, Long Tab	3
106	43513	NBR	Seal, Low-Pressure with SS-Spring	3
110	132956	BBCP	Manifold, Seal	1
112	11373	NBR	O-Ring, Inlet Manifold-70D	4
117	44585	S	Screw, HSH (M14 x 40) (See Tech Bulletin 074)	4
118	48702	S	Plug (1/4" NPT[M])	2
126	132958	PTFB	Adapter, Female	3
127	43516	SNG	V-Packing	9
128	43517	BB	Adapter, Male	3
136	132964	BB	Retainer, Valve Assembly	3
155	14200	NBR	O-Ring, Valve Spacer-70D	6
156	132960	PTFE	Backup Ring, Valve Spacer	6
157	132959	BB	Spacer, Valve	3
162	48510	PTFE	Backup Ring, Valve Seat	6
163	11338	NBR	O-Ring, Valve Seat-70D	6
164	132965	S	Seat, Valve	6
166	48793	SS	Valve	6
167	43751	S	Spring	6
168	44564	PVDF	Retainer, Spring	6
172	14179	NBR	O-Ring, Valve Plug-70D	3
173	49850	PTFB	Backup Ring, Valve Plug	3
174	132966	BB	Plug, Valve	3
177	128261	S	Screw, HSH (M12 x 35) (See Tech Bulletin 074)	8
178	670086	BB	Cover, Valve	1
185	132962	BBCP	Manifold, Inlet/Discharge, Block-Style	1
186	19935	SCP	Washer (M12)	16
188	128035	S	Screw, HSH (M12 x 110) (See Tech Bulletin 074)	8
250	855042	NY	Protector, Shaft with 2 Screws, Lockwashers and Washers (Included with Pump) (See Tech Bulletin 125)	1

Italics are optional items. R Components comply with RoHS Directive.

[] Date of latest production change For additional technical information see www.catpumps.com/literature/tech-bulletins.

MATERIAL CODES (Not Part of Part Number): ABS=ABS Plastic ALE=Aluminum Epoxy

BB=Brass BBCP= Brass/Chrome Plated CC=Ceramic CM=Chrome-Moly D=Acetal FBR=Fiber FCM=Forged Chrome-Moly NBR=Medium Nitrile (Buna-N)

NBR S=Buna, Silicone Free NY=Nylon PC=Poly Carbonate PE=Polyethylene POP=Polypropylene PPG=Glass Fitted Polypropylene PTFE=Pure Polytetrafluoroethylene

PTFB=Polytetrafluoroethylene w/60% Bronze PVDF=PolyvinylideneFluoride S=304SS SCP=304SS/Chrome-Plated SNG=Special Blend (Buna)

SS=316SS SHB=304SS/High Strength Brass STCP=Steel/Chrome Plated STL=Steel STZP=Steel/Zinc Plated

TNM=Special High Strength ZP=Zinc Plated

Optional Parts and Accessories and Service parts listed on Page 3. Standard and optional Seal and Valve Kits listed on page 4.

EXPLODED VIEW

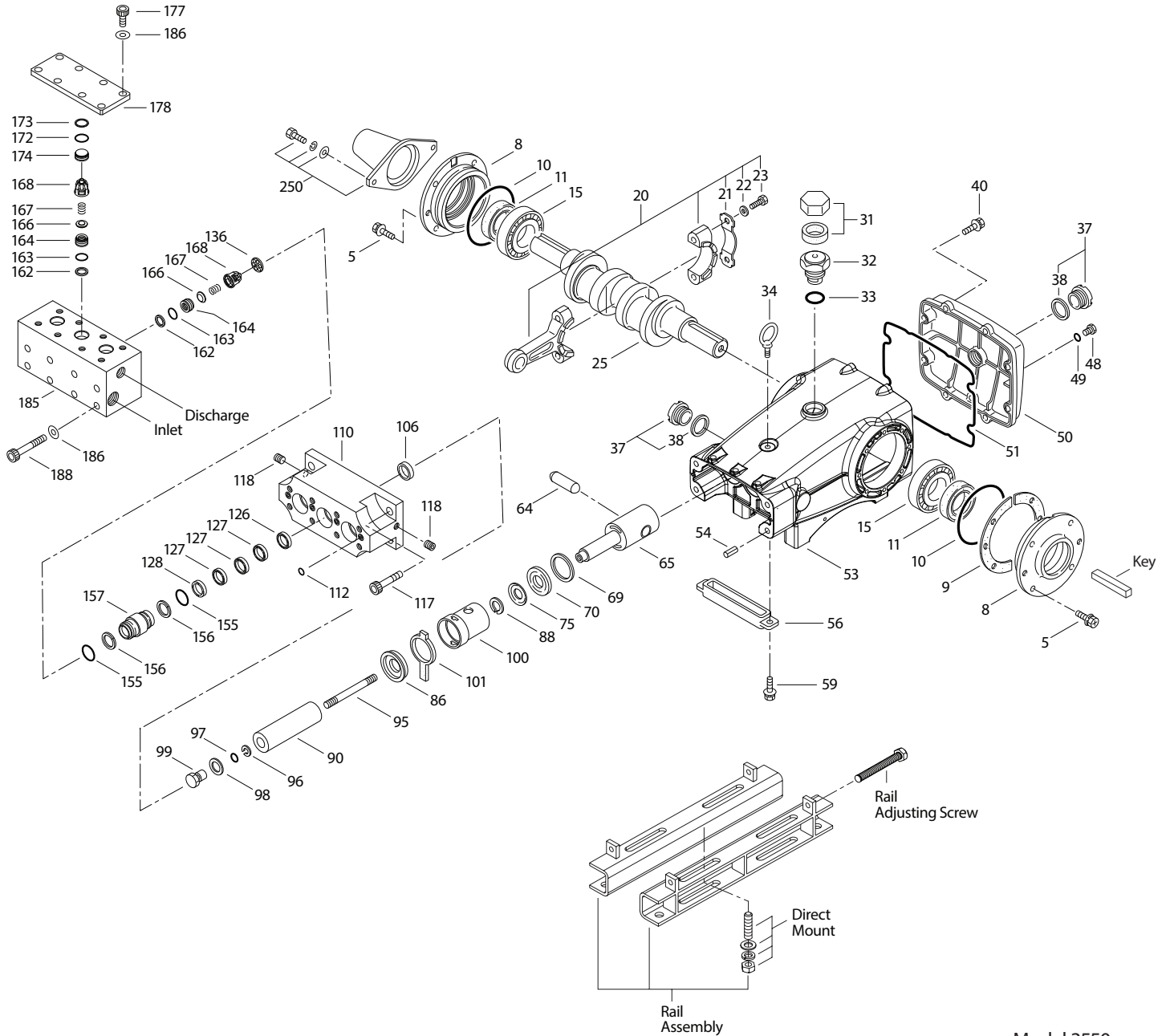

Model 3550
January 2023

OPTIONAL PARTS AND ACCESSORIES

PART	DESCRIPTION	QTY
34021	Key (M10 x 8 x 70)	1
92674	Mount, Rail Assembly (STZP R)	1
34018	Mount, Direct (STZP R)	1
990013	Hub, "B", 35 mm (STL)	1
80540	Screwing, Adjusting (M12 x 100)	2
30278	Oiler (1 oz) (Not Shown)	3
34314	Kit, Oil Drain (3/8" x 48") (Not Shown)	1
30696	Pliers, Reverse	1

SERVICE PARTS

PART	DESCRIPTION	QTY
76982	Kit, Seal – Standard NBR	1
77033	Kit, Valve – Standard NBR	2
6100	Oil, Case (12–21 oz bottle) (Fill to Specified Crankcase Capacity Prior to Start-up)	1
6124	Gasket, Liquid (3 oz)	1
818608	Head, Complete – with NBR Seals and O-Rings	1

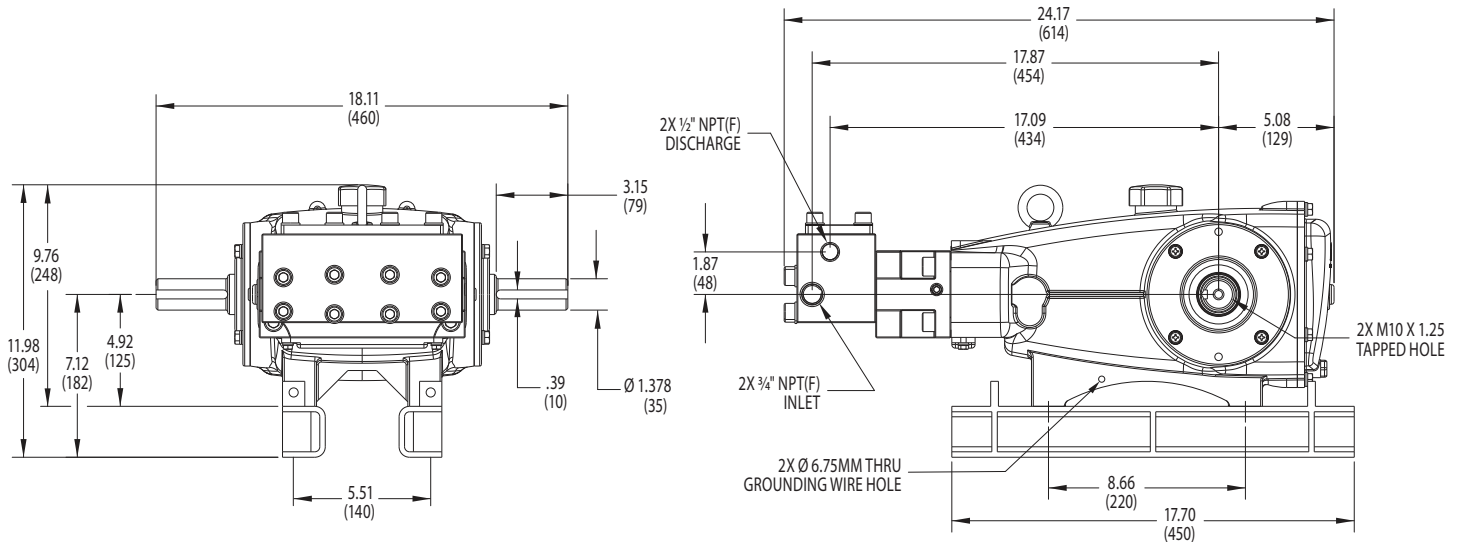

SEAL KITS One (1) seal kit required per pump

PUMP MODELS	NBR (STD)	NBR* (.3000)
3550	76982	77069

ITEM (Included in Seal Kits)			DESCRIPTION	QTY
97	14190	14190	O-Ring, Plunger Retainer	3
106	43513	43513	Seal, Low-Pressure with SS-Spring	3
112	11373	11373	O-Ring, Inlet Manifold	4
126	132958	132958	Adapter, Female	3
127	43516	44607	V-Packing	9
155	14200	14200	O-Ring, Valve Spacer	6
156	132960	132960	Backup Ring, Valve Spacer	6

*Review material codes for individual items (STG generally may be used as an alternative)

VALVE KITS Two (2) valve kits required per pump

PUMP MODELS	NBR (STD)	NBR (.3000)
3550	77033	77033

ITEM (Included in Valve Kits)			DESCRIPTION	QTY
162	48510	48510	Backup Ring, Valve Seat	3
163	11338	11338	O-Ring, Valve Seat	3
164	132965	132965	Seat	3
166	48793	48793	Valve	3
167	43751	43751	Spring	3
168	44564	44564	Retainer, Spring	3
172	14179	14179	O-Ring, Valve Plug	3
173	49850	49850	Backup Ring, Valve Plug	3

⚠ CAUTIONS AND WARNINGS

All high-pressure systems require a primary pressure regulating device (e.g. regulator, unloader) and a secondary pressure relief device (e.g. pop-off valve, relief valve). Failure to install such relief devices could result in personal injury or damage to pump or property. Cat Pumps does not assume any liability or responsibility for the operation of a customer's high-pressure system. Read all CAUTIONS and WARNINGS before commencing service or operation of any high-pressure system. The CAUTIONS and WARNINGS are included in each Service Manual and with each Accessory Data sheet. CAUTIONS and WARNINGS can also be viewed online at www.catpumps.com/dynamic-literature/cautions-and-warnings or can be requested directly from Cat Pumps.

WARRANTY

View the Limited Warranty online at www.catpumps.com/literature/cat-pumps-limited-warranty