

MODEL 351.C02



SPECIFICATIONS	U.S. Measure	Metric Measure
Flow	1.22 gpm	4.6 lpm
Pressure Range	400–1500 psi	28–103 bar
Pump RPM*	450 rpm	450 rpm
Inlet Pressure Range**	300–750 psi	21–52 bar
Min. Liquid Temperature**	-20° F	-29° C
Bore	0.787"	20 mm
Stroke	0.472"	12 mm
Crankcase Capacity	18 oz	0.53 l

SPECIFICATIONS	U.S. Measure	Metric Measure
Inlet Ports (2)	½" NPT(F)	½" NPT(F)
Discharge Ports (2)	¾" NPT(F)	¾" NPT(F)
Shaft Diameter	0.787"	20 mm
Pulley Mounting	Either Side	Either Side
Weight	19.8 lbs	9 kg
Dimensions	11.69 x 10.0 x 5.28"	297 x 254 x 134 mm

* Pump minimum is 100 RPM

** Temperature and pressure must be maintained to keep incoming CO₂ in a liquid state.

EXPLODED VIEW

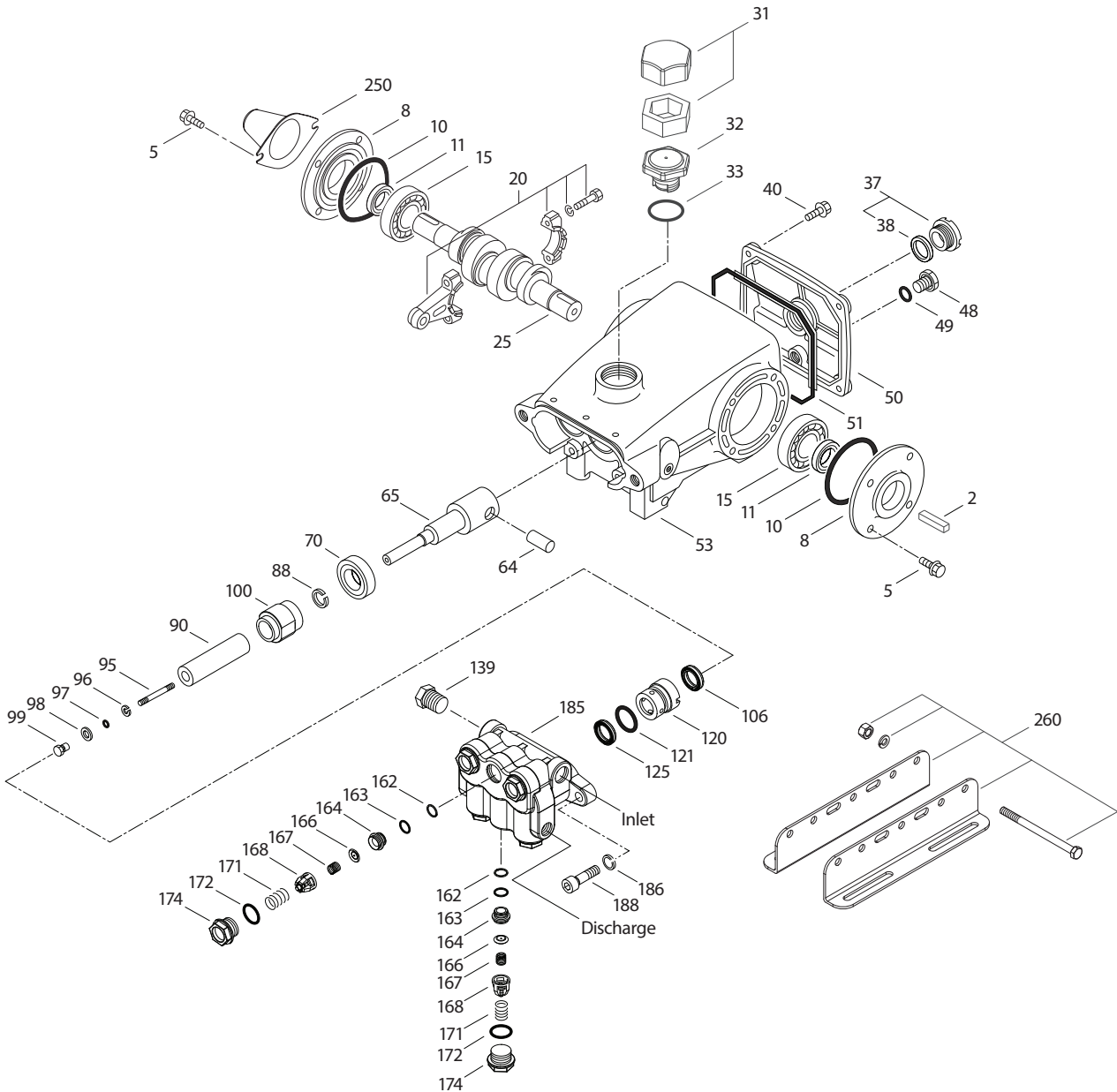

(Parts List on Reverse Side)

April 2026

PARTS LIST

ITEM	PN	MATL	DESCRIPTION	QTY
2	30057	STL	Key (M6 x 6 x 25)	1
5	92538	S	Screw, HHC Sems (M6 x 16) (See Tech Bulletin 074)	8
8	43344	AL	Cover, Bearing	2
10	43343	NBR	O-Ring, Cover, Bearing	2
11	43222	NBR	Seal, Oil, Crankshaft	1
15	14480	STL	Bearing, Ball	2
20	45883	HS	Rod, Connecting (See Tech Bulletin 074)	3
25	43838	FCM	Crankshaft, Dual-End (M12)	1
31	828710	PE	Protector, Oil Cap with Foam Gasket	1
32	43211	ABS	Cap, Oil Filler	1
33	14177	NBR	O-Ring, Filler Cap	1
37	92241	PC	Gauge, Oil, Bubble with Gasket (See Tech Bulletin 074)	1
38	44428	NBR	Gasket, Flat, Oil Gauge	1
40	92542	S	Screw, HHC Sems (M6 x 20) (See Tech Bulletin 074)	4
48	25625	STCP	Plug, Drain (1/4" x 19 BSP)	1
49	23170	NBR	O-Ring, Drain Plug	1
50	48772	AL	Cover, Rear	1
51	48773	NBR	O-Ring, Rear Cover	1
53	48769	AL	Crankcase	1
64	43351	CM	Pin, Crosshead	3
65	45256	SSZZ	Rod, Plunger	3
70	43228	NBR	Seal, Oil, Crankcase	3
88	45697	S	Washer, Keyhole (M18 x M10)	3
90	43367	CC	Plunger (M20 x 72)	3
95	89653	SS	Stud, Plunger Retainer (M6 x 58)	3
96	43235	PTFE	Backup Ring, Plunger Retainer	3
97	17399	NBR	O-Ring, Plunger Retainer	3
98	44041	SS	Gasket, Plunger Retainer (12.5mm)	3

ITEM	PN	MATL	DESCRIPTION	QTY
99	44031	SS	Retainer, Plunger (M6) (See Tech Bulletin 074)	3
100	701765	SS	Retainer, Seal	3
106	701763	SFTA	Seal, Low-Pressure with NIH-Spring	3
120	45680	SS	Case, Seal (See Tech Bulletin 074)	3
121	14200	NBR	O-Ring, Seal Case	3
125	701764	SFTA	Seal, High-Pressure with NIH-Spring	3
139	45156	SS	Plug, Inlet (1/2" NPT[M])	1
162	48361	D	Backup Ring, Seat	6
163	43358	NBR	O-Ring, Seat	6
164	44128	SS	Seat	6
166	543669	SS	Valve	6
167	44056	SS	Spring	6
168	44565	PVDF	Retainer, Spring	6
171	44832	S	Spring, Coil	6
172	49382	NBR	O-Ring, Valve Plug	6
174	49296	SS	Plug, Valve (See Tech Bulletin 074)	6
185	45151	SS	Head, Manifold	1
186	15847	S	Lockwasher (M10)	2
188	87950	S	Screw, HSH (M10 x 35) (See Tech Bulletin 074)	2
250	118672	STCP	Protector, Shaft	1
255	30243	STZP	Mount, Direct (Not Shown)	1
260	30611	STZPR	Mount, Rail, Assembly	1
275	30944	STL	Hub "H", Key Assembly (Includes: 30945, 30057) (Not Shown)	1
283	34334	—	Kit, Oil Drain (3/8" x 48") (Not Shown)	1
300	76152	NBR*	Kit, Seal (Includes: 97, 106, 121, 125)	1
310	31152	NBR	Kit, Valve (Includes: 162, 163, 164, 166, 167, 168, 171, 172)	2
—	6107	—	Oil, Bottle (21 oz) (Fill to Specified Crankcase Capacity Prior to Start-up)	1

*Review material codes for individual items (SFTA may be used as an alternative).

Italics are optional items. R Components comply with RoHS Directive. For additional technical information see www.catpumps.com/literature/tech-bulletins.

MATERIAL CODES (Not Part of Part Number): ABS=ABS Plastic AL=Aluminum CC=Ceramic CM=ChromeMoly D=Acetal FCM=Forged Chrome-Moly
 HS=High Strength NBR=Medium Nitrile (Buna-N) NIH=High Nickel Alloy PC=Poly Carbonate PE=Polyethylene PTFE=Pure Polytetrafluoroethylene
 PVDF=Polyvinylidene Fluoride S=304SS SS=316SS SFTA=Special Blend PTFE TAN STCP=Steel/Chrome Plated STL=Steel
 STZP=Steel/Zinc Plated SSZZ=316SS/Zamak

⚠ CAUTIONS AND WARNINGS

All high-pressure systems require a primary pressure regulating device (e.g. regulator, unloader) and a secondary pressure relief device (e.g. pop-off valve, relief valve). Failure to install such relief devices could result in personal injury or damage to pump or property. Cat Pumps does not assume any liability or responsibility for the operation of a customer's high-pressure system.

Read all CAUTIONS and WARNINGS before commencing service or operation of any high-pressure system. The CAUTIONS and WARNINGS are included in each Service Manual and with each Accessory Data sheet. CAUTIONS and WARNINGS can also be viewed online at www.catpumps.com/dynamic-literature/cautions-and-warnings or can be requested directly from Cat Pumps.

WARRANTY

View the Limited Warranty online at www.catpumps.com/literature/cat-pumps-limited-warranty