

DATA SHEET

STAINLESS STEEL POP-OFF VALVES



Stainless Steel Models: **9960, 9961, 9962**

High-Temperature Models: **9960S, 9961S, 9962S**



(Model 9960 shown)

FEATURES

- Specially designed valve and seat configuration eliminates weeping on both stainless steel and high-temperature models.
- Stainless steel models are rated to 180° F, while high-temperature "S" models can handle temperatures up to 240° F.
- Lightweight, compact design quickly and conveniently mounts directly into discharge line.

SELECTION

Select a pop-off valve to meet or exceed the flow and pressure requirements of the system.

INSTALLATION

The pop-off valve should mount to the discharge port of the pump manifold, opposite from the primary pressure regulating device. If unavailable, plumb the pop-off valve parallel to the high-pressure line upstream from the primary pressure regulating device. The bypass flow from the pop-off valve should be left open or drained to the floor. If the pop-off valve opens and relieves, the bypassing fluid needs to be visible to the operator so they can address the cause of the relief. Do not route the bypass flow from the pop-off valve back to a reservoir or the pump's inlet.

OPERATION

This pop-off valve provides backup protection to the primary pressure regulating device for complete pressure relief and maximum pump and system protection.

Note: The pop-off valve is a secondary pressure relief device. It does not replace a primary pressure regulating device like a pressure regulator or unloader.

SPECIFICATIONS

	U.S. Measure	Metric Measure
9960, 9960S		
System Pressure Range	300–1500 psi	20–103 bar
Maximum Relief Setting	1650 psi	114 bar
9961, 9961S		
System Pressure Range	1000–3000 psi	69–207 bar
Maximum Relief Setting	3300 psi	228 bar
9962, 9962S		
System Pressure Range	1000–4000 psi	69–275 bar
Maximum Relief Setting	4400 psi	303 bar

COMMON SPECIFICATIONS

	U.S.	Metric
Flow Range	0–6 gpm	0–23 lpm
Inlet Port	¼" NPT(M)	¼" NPT(M)
Maximum Operating Temperatures:		
Stainless Steel Models	180° F	82° C
High-Temperature Models	240° F	116° C
Hose Barb	¾"	¾"
Weight	2.79 oz	0.8 kg
Dimensions	0.75 x 2.375"	19 x 60 mm

PRESSURE ADJUSTMENT

Setting and adjusting the primary pressure regulating device and pop-off valve must be done while the system is running. Turning the internal adjusting screw clockwise with a ¼" hex key will increase the pressure setting. Turning the internal adjustment screw counter-clockwise will decrease the pressure setting.

Set the primary pressure regulating device to its minimum setting by turning the adjusting screw counter-clockwise. On the pop-off valve, turn the internal adjustment screw clockwise to the highest pressure setting, then counter-clockwise slightly so the valve is not bottomed out. With the system on and running, actuate the flow downstream. Adjust the primary pressure regulating device clockwise to increase the system operating pressure to the desired set point.

Note: If there is visible water coming from the pop-off valve bypass port during this process, continue to increase its setting.

With the system operating at full pressure, slowly turn the pop-off valve's adjusting screw counter-clockwise until a small amount of water is dripping from it. Adjust a half-turn clockwise until dripping stops; no more than three half-turns should be required. Cycle the downstream flow on and off a few times and check for any additional leaks. A closing trigger gun or solenoid valve may create a pressure spike and cause the pop-off valve to leak. Re-adjust as necessary. The pop-off valve is now set approximately 200 to 300 psi over the system pressure.

PARTS LIST

ITEM	P/N	MATL	DESCRIPTION	QTY
1	76934	STB	Seat	1
2	76954	S	Retainer, Seat	1
3	31128	D	Valve, Needle (Models: 9960, 9961, 9962)	1
	76974	S	Valve, Needle (Models: 9960S, 9961S, 9962S)	1
4	30956	S	Spring, Silver (1500 psi)	1
	30957	S	Spring, Blue (3000 psi)	1
	33957	STZP	Spring, Black (4000 psi)	1
5	—	SS	Body (1/4" NPT[M])	1
6	30959	BB	Adjuster, Pressure	1

Bold part numbers are unique to a particular model.

Material Codes (Not Part of Part Number): BB=Brass D=Acetal
 S=304SS SS=316SS STB=Special Blend PTFE
 STZP=Steel/Zinc Plated

TYPICAL POP-OFF VALVE INSTALLATION

1. Triplex Plunger Pump
2. Pressure Gauge
3. **Pop-Off Valve**
(Secondary Pressure Relief Device)
4. Pulsation Dampener
5. Pressure Regulator
(Primary Pressure Regulating Device)

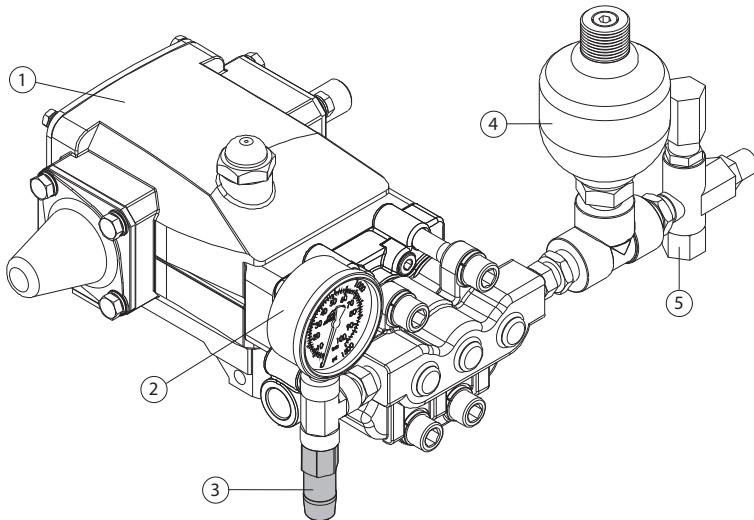

EXPLODED VIEW

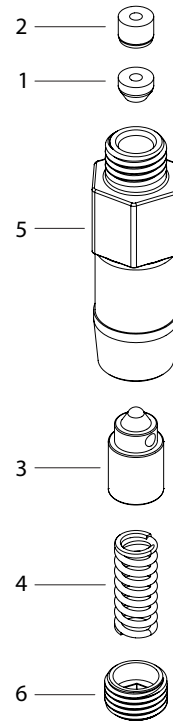

TROUBLESHOOTING

PROBLEM	PROBABLE CAUSE	SOLUTION
Valve cycles	Valve is improperly set.	Repeat adjustment procedure.
Valve continually bypasses	Seat or retainer is worn.	Replace as needed.

⚠ CAUTIONS AND WARNINGS

All high-pressure systems require a primary pressure regulating device (e.g. regulator, unloader) and a secondary pressure relief device (e.g. pop-off valve, relief valve). Failure to install such relief devices could result in personal injury or damage to pump or property. Cat Pumps does not assume any liability or responsibility for the operation of a customer's high-pressure system. Read all CAUTIONS and WARNINGS before commencing service or operation of any high-pressure system. The CAUTIONS and WARNINGS are included in each Service Manual and with each Accessory Data sheet. CAUTIONS and WARNINGS can also be viewed online at www.catpumps.com/dynamic-literature/cautions-and-warnings or can be requested directly from Cat Pumps.

WARRANTY

View the Limited Warranty online at www.catpumps.com/literature/cat-pumps-limited-warranty