

DATA SHEET

35 FRAME PLUNGER PUMP

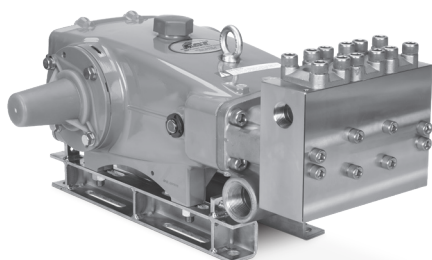

Model: 3560



Model 3560 Shown
(Mounting rails sold separately)

FEATURES

- Triplex plunger design ensures high efficiency and low pulsation.
- V-packings and low-pressure seals are completely lubricated and cooled by pumped liquid, greatly increasing service life.
- Special high-density, polished concentric plungers provide a true wear surface and extended seal life.
- Wet-end easily serviced without entering crankcase.
- Pump comes standard with NBR seals. Alternative seal materials are available for higher temperature or chemical compatibility.

SPECIFICATIONS	U.S. Measure	Metric Measure
Flow	20 gpm	76 lpm
Pressure Range	100–4000 psi	6.9–275 bar
Pump RPM*	1160 rpm	1160 rpm
Inlet Pressure Range	Flooded–70 psi	Flooded–4.8 bar
Max. Liquid Temperature (NBR)	160° F	71° C

Alternative seals available for higher temperatures up to 190° F

Bore	0.984"	25 mm
Stroke	1.890"	48 mm
Crankcase Capacity	4.2 qts	4 l
Inlets Ports (2)	1½" NPT(F)	1½" NPT(F)
Discharge Ports (2)	1" NPT(F)	1" NPT(F)
Pulley Mounting	Either Side	Either Side
Shaft Diameter	1.378"	35 mm
Weight	142 lbs	64.4 kg
Dimensions	23.54 x 18.11 x 9.88"	598 x 460 x 251 mm

*Pump minimum is 100 RPM.

ALTERNATE SPECIFICATIONS	U.S. Measure	Metric Measure
Flow	25 gpm	95 lpm
Pressure Range	100–3000 psi	6.9–210 bar
Pump RPM *	1450 rpm	1450 rpm

ALTERNATIVE SEAL CONFIGURATION

MATERIAL	SUFFIX CODE	MAXIMUM TEMPERATURE	
NBR	—	160° F	(71° C)
FPM	.0110	180° F	(82° C)
STHT	.3400	190° F	(88° C)

See **Tech Bulletin 002** for inlet conditions and RPM at high temperature.

DETERMINING THE PUMP RPM	$\frac{\text{Rated gpm}}{\text{Rated rpm}}$	=	$\frac{\text{Desired gpm}}{\text{Desired rpm}}$
DETERMINING THE REQUIRED HP	$\frac{\text{hp (Electric Brake)}}{1460}$	=	$\frac{\text{gpm x psi}}{1460}$
DETERMINING MOTOR PULLEY SIZE	$\frac{\text{Motor Pulley OD}}{\text{Pump rpm}}$	=	$\frac{\text{Pump Pulley OD}}{\text{Motor rpm}}$

Refer to pump **Service Manual** for repair procedure and additional technical information.

PARTS LIST

ITEM	P/N	MATL	DESCRIPTION	QTY
5	96049	S	Screw, Sems (M10 x 25) (See Tech Bulletins 074)	8
8	134604	ALE	Cover, Bearing	2
9	815279	FBR	Shim, Split, 2-Piece	0-2
10	12398	NBR	O-Ring, Cover, Bearing	2
11	13296	NBR	Seal, Oil, Crankshaft	2
12	855049	S	Shim, Split, 2-Piece	0-2
15	29326	STL	Bearing, Roller	2
20	121467	TNM	Rod, Connecting (Includes: 21, 22, 23) (See Tech Bulletin 074)	3
21	126749	STCP R	Washer, Locking (M10)	3
22	126593	STCP R	Shim, Washer (M10.5 x 1.5)	6
23	122045	STZP	Screw, HH (M10 x 55)	6
25	29325	FCM	Crankshaft, Dual-End (M48)	1
31	828710	PE	Protector, Oil Cap with Foam Gasket	1
32	43211	ABS	Cap, Oil Filler	1
33	14177	NBR	O-Ring, Oil Filler Cap	1
34	126743	STCP R	Bolt, Eye (M12 x 1.75) (For Lifting Pump Only)	1
37	92241	PC	Gauge, Oil, Bubble with Gasket (See Tech Bulletin 074)	3
38	44428	NBR	Gasket, Flat, Oil Gauge	3
40	125753	S	Screw, HHC Sems (M8 x 25) (See Tech Bulletin 074)	8
48	25625	STCP	Plug, Drain (1/4" x 19 BSP)	1
49	23170	NBR	O-Ring, Drain Plug	1
50	45936	ALE	Cover, Rear	1
51	16612	NBR	O-Ring, Crankcase	1
53	134786	ALE	Crankcase Assembly (Includes: 54)	1
54	27488	S	Pins, Guide	2
56	27790	POP	Pan, Oil	1
59	92538	S	Screw, HHC Sems (M6 x 16)	2
64	43864	CM	Pin, Crosshead	3
65	49076	SHB	Rod, Plunger	3
69	126587	STCP R	Washer, Oil Seal	3
70	100488	NBRS	Seal, Oil, Crankcase	3
75	110669	S	Slinger, Barrier	3
88	110670	S	Washer, Keyhole (M16)	3
90	48535	CC	Plunger (M25 x 110)	3
95	126549	STCP R	Stud, Plunger Retainer (M7 x 103)	3
96	20184	PTFE	Backup Ring, Plunger Retainer	3
97	14190	NBR	O-Ring, Plunger Retainer	3
98	44069	SS	Gasket, Retainer	3
99	44068	SS	Retainer, Plunger (M7) (See Tech Bulletin 074)	3
100	855017	—	Retainer, Seal 2-Piece	3
101	44096	—	Wick, Long Tab	3
106	44086	NBR	Seal, Low-Pressure, with SS-Spring	3
110	49759	FBB	Manifold, Inlet	1
112	11379	NBR	O-Ring, Inlet Manifold	3
117	44585	S	Screw, HSH (M14 x 40) (See Tech Bulletin 074)	4
126	48538	BB	Adapter, Female	3
127	† 44610	STG	V-Packing	6
128	48539	BB	Adapter, Male	3
155	17629	NBR	O-Ring, Spacer V-Packing	6
156	28243	PTFE	Backup Ring, Spacer V-Packing	6
157	49082	BB	Spacer, V-Packing	3
160	49092	NBR	O-Ring, Seat, Inlet	3
161	49091	S	Seat, Inlet	3
162	49088	PTFE	Backup Ring, Discharge Seat	3
163	49087	NBR	O-Ring, Seat, Discharge	3
164	49086	S	Seat, Discharge	3
165	49090	PVDF	Retainer, Spring, Inlet	3
166	49089	S	Valve	6
167	44109	SS	Spring	6
168	49085	PVDF	Retainer, Spring, Discharge	3
172	18690	NBR	O-Ring, Valve Plug	3
173	20369	PTFE	Backup Ring, Valve Plug	3
174	49093	BB	Plug, Valve	3
175	550176	S	Screw, HSH (M14 x 35) (See Tech Bulletin 074)	12
185	49084	SS	Manifold, Discharge	1
188	49045	S	Screw, HSH (M12 x 95) (See Tech Bulletin 074)	8
250	855042	POP	Protector, Shaft with 2-Screws, Lockwashers and Washers (Included with Pump)	1

Italics are optional items.

(STG generally may be used as alternate). R Components comply with RoHS Directive.

† Production parts are different than repair parts. For additional technical information see www.catpumps.com/literature/tech-bulletins.

MATERIAL CODES (Not Part of Part Number): ABS=ABS Plastic ALE=Aluminum Epoxy BB=Brass BBSS=Brass/316SS CC=Ceramic
 CM=Chrome-Moly F=Cast Iron FBB=Forged Brass FBR=Fiber FCM=Forged Chrome-Moly FPM=Fluorocarbon NBR=Medium Nitrile (Buna-N)
 NBRS=Buna, Silicone Free PC=Poly Carbonate PE=Polyethylene POP=Polypropylene PTFE=Pure Polytetrafluoroethylene
 PVDF=Polyvinylidene Fluoride S=304SS SS=316SS SHB=304SS/High Strength Brass STCP=Steel/Chrome Plated STG=Special Blend PTFE White
 STHT=Special PTFE High Temp STL=Steel STZP=Steel/Zinc Plated TNM=Special High Strength

EXPLODED VIEW

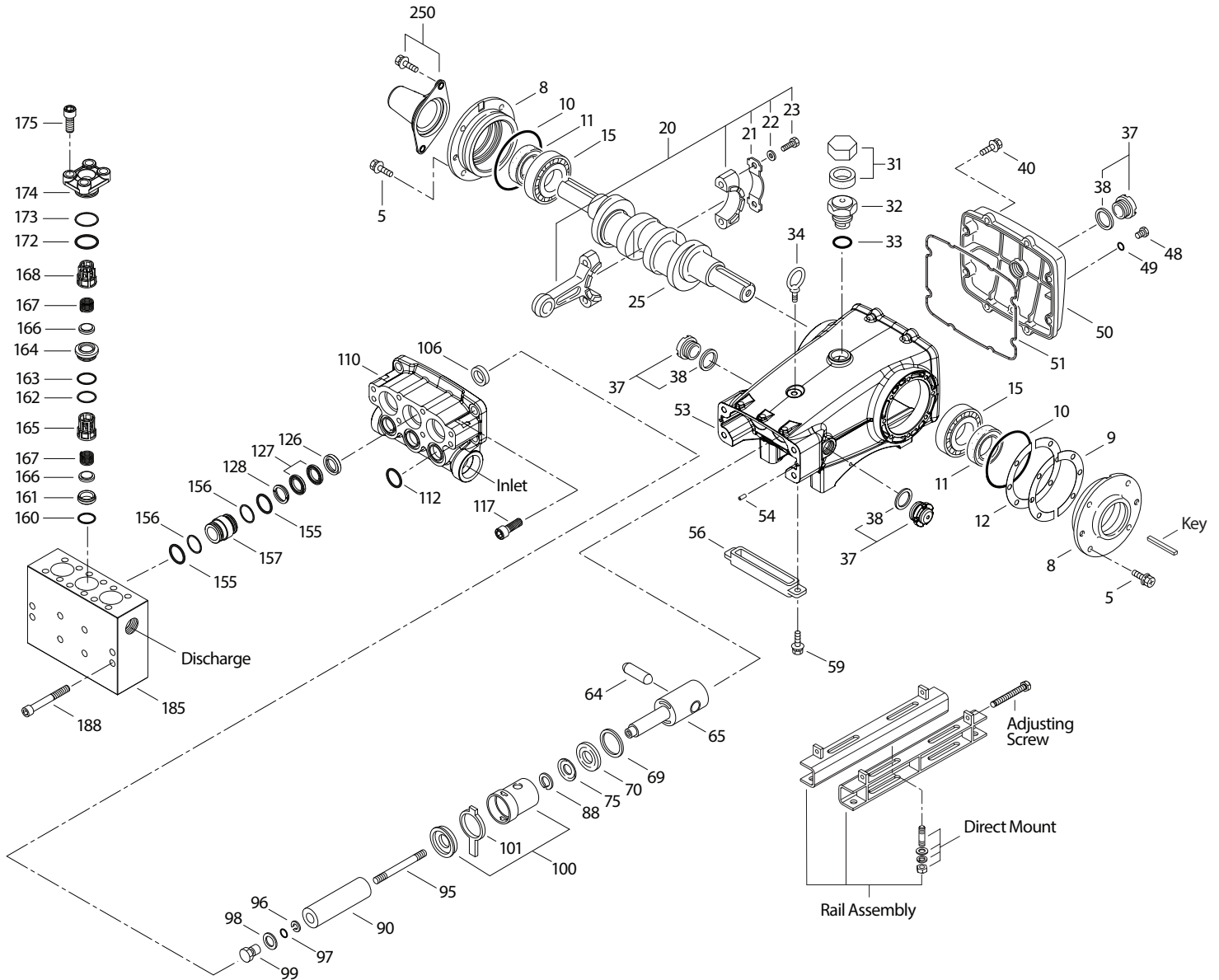

Model 3560
April 2026

OPTIONAL PARTS AND ACCESSORIES

PART	DESCRIPTION	QTY
34021	Key (M10 x 8 x 70)	1
92674	Mount, Rail Assembly (Includes: 34018)	1
34018	Mount, Direct (Includes: 34018)	1
990013	Hub, "B", 35 mm (Not Shown)	1
80540	Screw, Adjusting (M12 x 100)	2
34334	Kit, Oil Drain (3/8" x 24") (Not Shown)	1
819000	Assembly, Crankcase, Cast Iron Conversion (Not Shown)	1

SERVICE PARTS

PART	DESCRIPTION	QTY
31280	Kit, Seal – Standard NBR	1
31292	Kit, Valve – Standard NBR	1
6100	Oil, Case (12 - 21 oz bottles) (Fill to Specified Crankcase Capacity Prior to Start-Up)	1
6106	Lubricant, Anti-Seize (2 mL)	1
6139	Lubricant, Anti-Seize (8 oz)	1
32273	Crankcase Oil Seal Removal and Installation Kit (Not Shown) (Includes: Oil Seals, Guide Tool, Screws, Washers, Driver)	1
30696	Plier, Reverse	1
816958	Head, Complete with NBR Seals and O-Rings	1

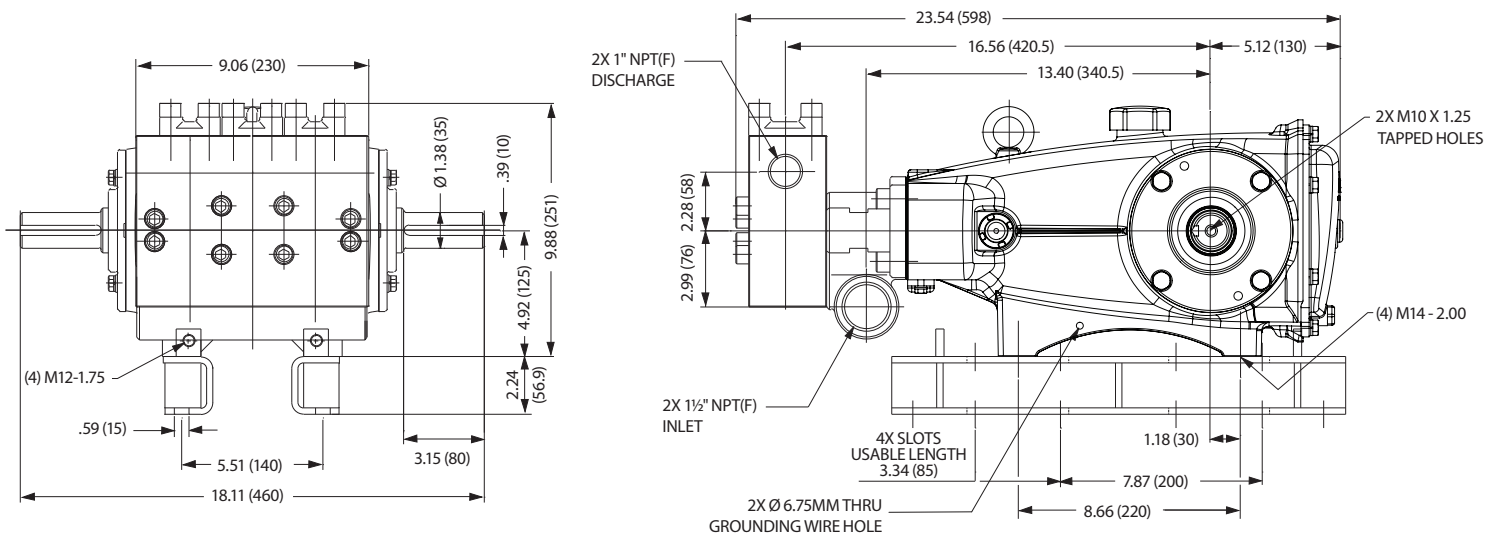

SEAL KITS One (1) seal kit required per pump

PUMP MODELS	NBR (STD)	FPM (0.0110)	STHT (.3400)
3560	31280 *	31380 *	76376 *

ITEM (Included in Seal Kits)				DESCRIPTION	QTY
97	14190	14161	14190	O-Ring, Plunger Retainer	3
106	44086	45846	76086	Seal, Low-Pressure, with SS-Spring	3
112	11379	14183	11379	O-Ring, Inlet Manifold	3
127	44610	44610	44610	V-Packing	6
155	17629	14183	17629	O-Ring, V-Packing Spacer	6
156	28243	28243	28243	Backup Ring, V-Packing Spacer	6

*Review material codes for individual items (ST2, STG may be used as alternative)

VALVE KITS One (1) valve kit required per pump

PUMP MODELS	NBR (STD)	FPM (0.0110)	STHT (.3400)
3560	31292	31296	31292

ITEM (Included in Valve Kits)				DESCRIPTION	QTY
160	49092	49155	49092	O-Ring, Seat, Inlet	3
161	49091	49091	49091	Seat, Inlet	3
162	49088	49088	49088	Backup Ring, Discharge Seat	3
163	49087	49154	49087	O-Ring, Discharge Seat	3
164	49086	49086	49086	Seat, Discharge	3
165	49090	49090	49090	Retainer, Spring, Inlet	3
166	49089	49089	49089	Valve	6
167	44109	44109	44109	Spring	6
168	49085	49085	49085	Retainer, Spring, Discharge	3
172	18690	11744	18690	O-Ring, Valve Plug	3
173	20369	20369	20369	Backup Ring, Valve Plug	3

⚠ CAUTIONS AND WARNINGS

All high-pressure systems require a primary pressure regulating device (e.g. regulator, unloader) and a secondary pressure relief device (e.g. pop-off valve, relief valve). Failure to install such relief devices could result in personal injury or damage to pump or property. Cat Pumps does not assume any liability or responsibility for the operation of a customer's high-pressure system. Read all CAUTIONS and WARNINGS before commencing service or operation of any high-pressure system. The CAUTIONS and WARNINGS are included in each Service Manual and with each Accessory Data sheet. CAUTIONS and WARNINGS can also be viewed online at www.catpumps.com/dynamic-literature/cautions-and-warnings or can be requested directly from Cat Pumps.

WARRANTY

View the Limited Warranty online at www.catpumps.com/literature/cat-pumps-limited-warranty