



# TECH BULLETIN

017  
05/80

*Published regarding engineering changes and improvements*

## SUBJECT: Shimming of Discharge Manifolds

The shims on the cylinder bolts are used in some models to compensate for the manufacturing tolerances of the various parts. When the discharge manifold is tightened against the shims, the cylinders, discharge valves and spring retainers are held tight against the counterbore in the manifold. If there are too many shims, there will be movement of the cylinder and internal leakage by the discharge valve seat and cylinder causing pulsation and lower output. If there are too few shims, there is the possibility of distorting the manifold. Once the proper shims have been determined, the manifold can be removed to work on valves or pistons and replaced without re-shimming. **Once the discharge manifold is replaced, it is necessary to recheck the shims, to compensate for the manufacturing tolerances of the new manifold.** To re-shim, use the following procedure:

1. Remove all shims from the cylinder bolts.
2. With all the pump components assembled, slip the discharge manifold complete with discharge valve assembly onto the cylinder bolts. Thread the cylinder bolt/nuts on finger tight.
3. With a caliper, measure the gap between the discharge manifold and the shoulder of the cylinder bolt. (See sketch) If a caliper is not available, make up a shim pack of various sizes to measure the gap.
4. Select the shims that will be [.005 to .010 inches] [.15 to .25 mm] less than the measured gap. Shims come in .039, .019, and .012 inch [1.0, 0.5 and 0.3 mm] thickness. **Make certain that thickness of the retainer washer is counted in the total shim package.** Remove the discharge manifold, install the shim package onto the cylinder bolts and replace the manifold. Install the lockwashers and nuts and torque to the following specs:

### TORQUE CHART

Model	in./lbs.	ft./lbs.	Nm
280, 333, 430	115	9.4	13
10 Frame	220	18.1	25
25 Frame	350	28.9	40

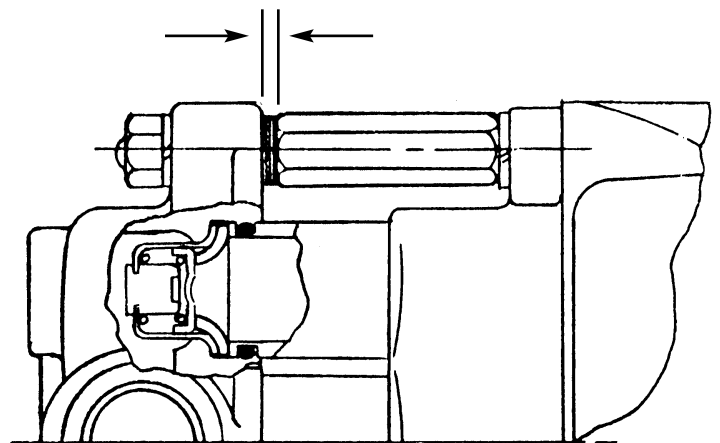

CAT PUMPS  
Technical Services Department

Rev. 02/96