

# TECH BULLETIN 125



## Product changes to crankcase, bearing covers, and shaft protector for all 35 and 38 Frame plunger pumps

Changes have been made to the crankcase and mounting hardware to better support the weight of direct drive bell housings. This affects all 35 and 38 frame plunger pumps with date codes/serial numbers after June 2018.

### Improvements:

- Crankcase bell housing mounting bolt holes number increased from four (4) to eight (8) to better distribute weight of motor on crankcase.
- Bell housing mounting bolt quantity and sizes changed from four (4) M8 to eight (8) M10 bolts.
- M8-sized grounding wire mounting holes (6.75mm x 12mm depth) have been added on both sides of the crankcase.

### Functionality Changes:

- Rotated threaded M10 jacking screw hole locations to coincide with the incorporation of additional mounting holes.
- Bearing cover bolt holes enlarged (Four [4] x M11) to accommodate M10 bolt size.
- Shaft protector bolt holes enlarged (Two [2] x M11) to accommodate M10 bolt size.

### New Crankcase Style

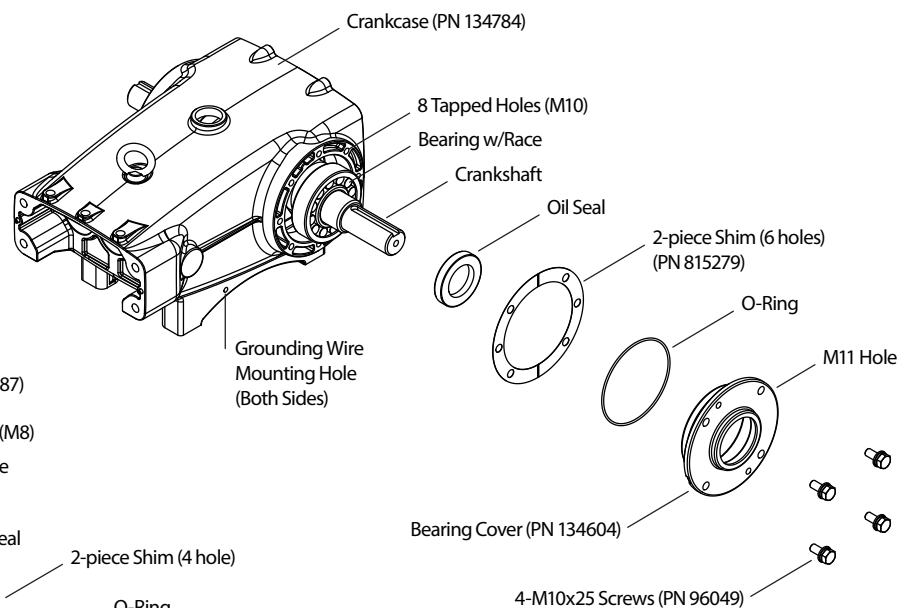

### Old Crankcase Style

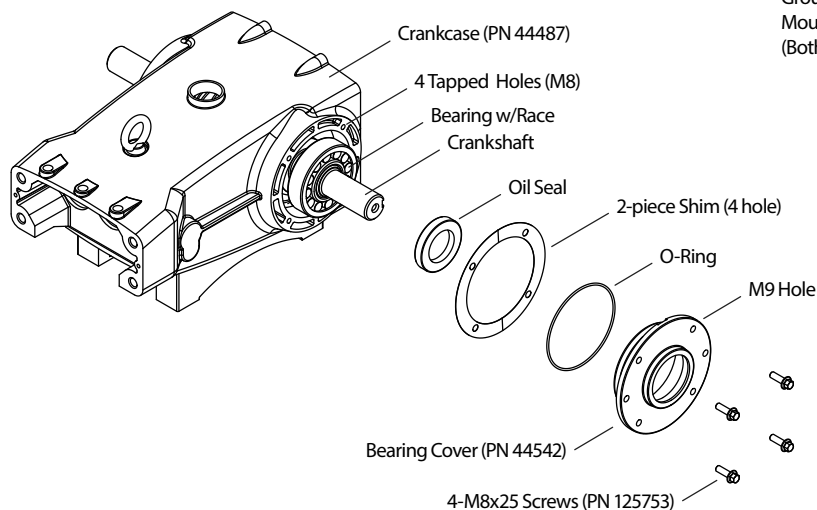

### Cat Pumps

Technical Services Department

99TCH125 Rev A 9/18