

DATA SHEET

DIRECT DRIVE PLUNGER PUMPS



Stainless Steel Models:

2SFQ25SEEL, 2SFQ29SEEL, 2SFQ35SEEL, 2SFQ42SEEL

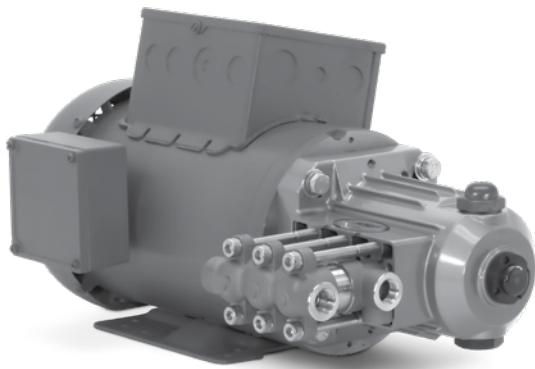

Motorized pump unit 2SFQ42SEEL251 Shown

SPECIFICATIONS	U.S. Measure	Metric Measure
2SFQ25SEEL		
Flow	2.5 gpm	9.5 lpm
Stroke	0.287"	7.3 mm
2SFQ29SEEL		
Flow	2.85 gpm	10.8 lpm
Stroke	0.335"	8.5 mm
2SFQ35SEEL		
Flow	3.5 gpm	13.2 lpm
Stroke	0.402"	10.2 mm
2SFQ42SEEL		
Flow	4.2 gpm	15.9 lpm
Stroke	0.402"	10.2 mm

FEATURES

- Unique spring loaded inlet valves and the flow through ceramic plungers provides a smooth, steady flow.
- Hollow shaft direct drive to provide the smallest possible footprint for challenging spaces.
- "Q" feature is designed for applications where a reduced sound level is desirable.

COMMON

SPECIFICATIONS	U.S.	Metric
Pressure Range	100 - 1200 psi	6.9 - 83 bar
Pump RPM	1725 rpm	1725 rpm
Inlet Pressure Range	Flooded to 60 psi	Flooded to 4.1 bar
Max. Liquid Temp. (NBR)	160° F	71° C
Alternative seals available for high temp up to 200° F		
Bore	0.709"	18 mm
Bore (2SFQ42SEEL only)	0.789"	20 mm
Crankcase Capacity	10.1 oz	0.30 l
Inlet Port (1)	3/8" NPT(F)	3/8" NPT(F)
Discharge Ports (2)	3/8" NPT(F)	3/8" NPT(F)
By-Pass Return Port (1)	1/4" NPT(F)	1/4" NPT(F)
Shaft Diameter	5/8"	15.9 mm
Weight (Pump Only)	8.9 lbs	4 kg
Dimensions (Pump Only)	6.8 x 8.7 x 5.2"	173 x 221 x 133 mm

ALTERNATIVE SEAL CONFIGURATION

MATERIAL	SUFFIX CODE	MAXIMUM TEMPERATURE
NBR	—	160° F (71° C)
FPM	.0110	180° F (82° C)
EPDM	.0220	160° F (71° C)
IPFE	.0770	200° F (93° C)
HT	.3000	190° F (88° C)
STHT	.3400	200° F (93° C)

See Reference Document 99REF017 for inlet conditions and RPM at high temperature.

DETERMINING THE PUMP R.P.M.

$$\frac{\text{Rated gpm}}{\text{Rated rpm}} = \frac{\text{"Desired" gpm}}{\text{"Desired" rpm}}$$

DETERMINING THE REQUIRED H.P.

$$\text{Hp (Electric Brake)} = \frac{\text{gpm x psi}}{1460}$$

Refer to pump **Service Manual** for repair procedure and additional technical information.

PARTS LIST

ITEM	PART NUMBER	MATL	DESCRIPTION	MODEL USED	QTY
5	547445	S	Screw, HHC Sems (M6 X 14)	All	3
8	547153	AL	Cover, Bearing	All	1
10	14041	NBR	O-Ring, Bearing Cover - 70D	All	1
11	55337	NBR	Seal, Oil Crankshaft	All	1
15	14488	STL	Bearing, Ball - Inner	All	1
20	547046	TNM	Rod, Connecting	All	1
25	544693	CM	Crankshaft, 7.3 mm	2SFQ25SEEL	1
	45914	CM	Crankshaft, 8.5 mm	2SFQ29SEEL	1
	544694	CM	Crankshaft, 10.2 mm	2SFQ35SEEL, 2SFQ42SEEL	1
26	12385	STL	Ring, Retaining, Bearing	All	1
27	15710	STL	Bearing, Ball - Outer	All	1
31	549726	—	Cap, Vented w/O-Ring (rain cap)	All	1
32	547961	RTP	Cap, Oil Filler w/O-Ring	All	1
33	14179	NBR	O-Ring, Oil Filler Cap - 70D	All	1
37	92241	—	Gauge, Oil w/Gasket - 80D	All	1
38	44428	NBR	Gasket, Flat, Oil Gauge - 80D	All	1
48	44842	NY	Plug, Drain	All	1
49	14179	NBR	O-Ring, Drain Plug - 70D	All	1
52	833820	SSSS	Pin, Guide	All	2
53	833819	AL	Crankcase	All	1
64	16948	CM	Pin, Crosshead	All	3
65	834203	SSTO	Rod, Plunger	All	3
69	126259	STCP R	Washer, Oil Seal	All	3
70	25461	NBR	Seal, Oil Crankcase	All	3
90	544697	CC	Plunger, Ceramic (M18 x 18)	2SFQ25SEEL – 2SFQ35SEEL	3
	831290	CC	Plunger, Ceramic (M20 x 18)	2SFQ42SEEL	3
100	44869	PVDF	Retainer, Seal	All	3
106	547683	NBR	Seal, LPS w/SS - Spg	All	3
	545192	FPM	Seal, LPS w/SS-Spg	All	3
	◆ 546507	EPDM	Seal, LPS w/SS-Spg	All	3
	76443	ST	Seal, LPS	All	3
110	833996	SS	Manifold, Inlet	2SFQ25SEEL – 2SFQ35SEEL	1
	833822	SS	Manifold, Inlet	2SFQ42SEEL	1
125	833997	SNG	Seal, HPS	2SFQ25SEEL – 2SFQ35SEEL	3
	833824	SNG	Seal, HPS	2SFQ42SEEL	3
134	33873	D	Valve, Inlet	2SFQ25SEEL – 2SFQ35SEEL	3
	833821	D	Valve, Inlet	2SFQ42SEEL	3
135	543689	SS	Spacer	All	3
136	543690	SS	Spring, Inlet Valve	All	3
137	88575	S	Washer, Conical (M6)	All	3
138	543692	SS	Nut (M6)	All	3
152	23172	NBR	O-Ring, Adapter, Spacer, Inner - 70D	2SFQ25SEEL – 2SFQ35SEEL	3
	549539	NBR	O-Ring, Adapter, Spacer, Inner - 70D	2SFQ42SEEL	3
157	544700	SS	Adapter, Valve	2SFQ25SEEL – 2SFQ35SEEL	3
	831289	SS	Adapter, Valve	2SFQ42SEEL	3
159	23172	NBR	O-Ring, Adapter, Spacer, Outer - 70D	All	3
164	544293	SS	Seat	All	3
166	833825	D	Valve	All	3
167	543700	SS	Spring	All	3
168	44565	PVDF	Retainer, Spring	All	3
185	547705	SS	Manifold, Discharge	All	1
188	544701	S	Screw, HSH (M8 X 80)	All	6
255	30517	STZP R	Assy, Bolt Mount	All	1
285	80228	STL	Screw (M8 X 1.25 X 80) (Not Shown)	All	2
300	76273	NBR	Kit, Seal (Incls: 106, 125, 152, 159)	2SFQ25SEEL – 2SFQ35SEEL	1
	76265	NBR	Kit, Seal (Incls: 106, 125, 152, 159)	2SFQ42SEEL	1
310	76282	NBR	Kit, Valve (Incls: 152, 159, 164, 166, 167, 168)	2SFQ25SEEL – 2SFQ35SEEL	1
	76274	NBR	Kit, Valve (Incls: 152, 159, 164, 166, 167, 168)	2SFQ42SEEL	1
311	34974	NBR	Kit, Inlet Valve (Incls: 134 - 138, 152, 159)	2SFQ25SEEL – 2SFQ35SEEL	1
	76278	NBR	Kit, Inlet Valve (Incls: 134 - 138, 152, 159)	2SFQ42SEEL	1
352	44050	STZP R	Tool, Oil Gauge Removal	All	1
	6107	—	Oil, Bottle (21 oz.) ISO 68 Hydraulic (Fill to specified crankcase capacity prior to start up)	All	1

Bold print part numbers are unique to a particular pump model. *Italics are optional items.* R Components comply with RoHS Directive. ◆ Silicone Oil/Grease required.

View Tech Bulletins 002, 036, 043, 055, 064, 070, 073, 074, 091, 092, 095, 122 and 124 for additional information.

NOTE: Discard Key that may come standard with most motors and engines and use only the key included in Bolt kit.

MATERIAL CODES (Not Part of Part Number): AL=Aluminum CC=Ceramic CM=Chrome-Moly D=Acetal NBR=Medium Nitrile (Buna-N) NY=Nylon PVDF=Polyvinylidene Fluoride
RTP=Reinforced Composite S=304SS SNG=Special Blend (Buna) SS=316SS SSTO=316SS/Titanium Oxide STL=Steel STCP=Steel/Chrome Plated STZP=Steel/Zinc Plated
TNM=Special High Strength

MODEL	8105	8175	8110	8060	8062	8125/8125W
Dimension A	15.9	15.9	17.1	18.7	19.2	19.0
Dimension B	9.0	9.0	10.2	11.8	12.3	12.2
Dimension C	8.2	8.2	8.2	8.1	8.1	9.6
Dimension D	9.1	9.1	9.1	9.5	9.5	9.7

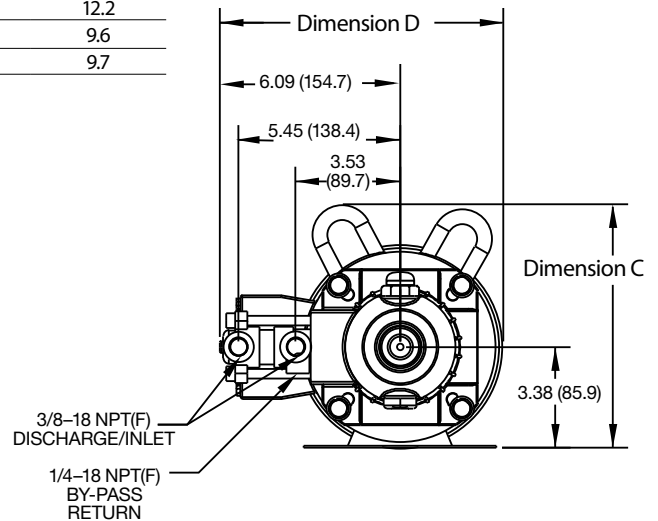
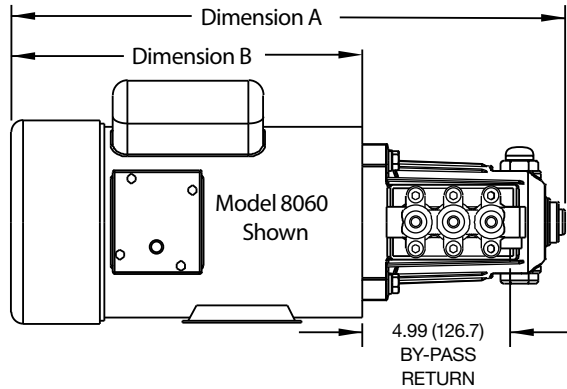

MOTOR SPECIFICATIONS

MODEL	8105	8175	8110	8060	8062	8125/8125W
HorsePower	0.5	0.75	1.0	1.5	2.0	2.5/2.2
Phase	Single	Single	Single	Single	Single	Single
RPM	1750	1745	1750	1725	1725	1750/1450
Frame Size	56C TEFC	56C TEFC	56C TEFC	56C TEFC	56C TEFC	56HC TEFC
Shaft Diameter	5/8"	5/8"	5/8"	5/8"	5/8"	5/8"
Maximum Volts	115/208-230	115/208-230	115/208-230	115/230	115/230	115/230 110/220
Full Load Amps	7.4/3.6-3.7	10.6/5.2-5.3	14/6.8-7.0	14.0/7.0	17.0/8.5	20.8/10.4 22/11
Hertz	60	60	60	60	60	60/50
Service Factor	1.15	1.15	1.15	1.2	1.15	1.15
Max. Ambient Temp.	104° F	104° F	104° F	104° F	104° F	104° F
Capacitor Start	Yes	Yes	Yes	Yes	Yes	Yes
Thermal Overload-Manual Reset	No	Yes	No	Yes	Yes	No
Weight (lbs.)	25	28	34	42	45.7	52.9

NOTE: Motor start-up AMPS may vary, then settle within FULL LOAD AMPS rating after initial run time.

★★ Before mounting pump on motor, apply P.N. 6106 Antiseize Lubricant to pump shaft.

Refer to Tech Bulletin 055 for instructions on removing pump from electric motor. For electric motor warranty consideration contact motor manufacturer's local authorized service center.

⚠ CAUTIONS AND WARNINGS

All High Pressure Systems require a primary pressure regulating device (i.e. regulator, unloader) and a secondary pressure relief device (i.e. pop-off valve, relief valve). Failure to install such relief devices could result in personal injury or damage to pump or property. Cat Pumps does not assume any liability or responsibility for the operation of a customer's high pressure system.

Read all CAUTIONS and WARNINGS before commencing service or operation of any high pressure system. The CAUTIONS and WARNINGS are included in each service manual and with each Accessory Data sheet. CAUTIONS and WARNINGS can also be viewed online at www.catpumps.com/cautions-warnings or can be requested directly from Cat Pumps.

WARRANTY

View the Limited Warranty on-line at www.catpumps.com/warranty.