

Model 5CP6221.44101 Shown  
(Rails and shaft protector sold separately)

# 5CP Stainless Steel Plunger Pump

Triethylene Glycol (TEG) Dehydration

## Models

**5CP6221.44101**  
**5CP6241CS.44101**  
**5CP6251.44101**

## FEATURES

- Designed for continuous-duty performance for triethylene glycol (TEG) gas dehydration where low life cycle costs are a must.
- Field tested, high pressure triplex pump configured for TEG temperatures up to 240° F (116° C).
- Positive displacement technology for optimum energy efficiency.
- Compact footprint enhances direct-drive gearbox and bell housing drives.

## COMMON SPECIFICATIONS

Bore .....	0.787"	(20 mm)
Crankcase Capacity .....	17 oz.	(0.53 l)
Maximum Liquid Temperature .....	240°F	(116°C)
Inlet Ports (2) .....	1/2" NPTF	(1/2" NPTF)
Discharge Ports (2) .....	3/8" NPTF	(3/8" NPTF)
Shaft Diameter .....	0.787"	(20 mm)
Weight .....	20 lbs.	(8 kg)
Dimensions .....	11.69 x 10.0 x 6.75"	(297 x 254 x 171 mm)

### ⚠ CAUTIONS AND WARNINGS

All High Pressure Systems require a primary pressure regulating device (i.e. regulator, unloader) and a secondary pressure relief device (i.e. pop-off valve, relief valve). Failure to install such relief devices could result in personal injury or damage to pump or property. CAT PUMPS does not assume any liability or responsibility for the operation of a customer's high pressure system.

Read all CAUTIONS and WARNINGS before commencing service or operation of any high pressure system. The CAUTIONS and WARNINGS are included in each service manual and with each Accessory Data sheet. CAUTIONS and WARNINGS can also be viewed online at [www.catpumps.com/cautions-warnings](http://www.catpumps.com/cautions-warnings) or can be requested directly from CAT PUMPS.

### WARRANTY

View the Limited Warranty on-line at [www.catpumps.com/warranty](http://www.catpumps.com/warranty).

## SPECIFICATIONS

U.S. Measure

Metric Measure

### MODEL 5CP6221.44101 Belt Drive

Flow .....	6.0 gpm	(23 lpm)
Pressure Range .....	100 to 2000 psi	(7 to 140 bar)
Inlet Pressure Range .....	-5 to 60 psi	(-0.35 to 4 bar)
RPM .....	1400 rpm	(1400 rpm)
Stroke .....	0.709"	(18 mm)

### MODEL 5CP6241CS.44101 Direct Drive

Flow .....	4.0 gpm	(15 lpm)
Pressure Range .....	100 to 2000 psi	(7 to 140 bar)
Inlet Pressure Range .....	Flooded to 60 psi	(Flooded to 4 bar)
RPM .....	1725 rpm	(1725 rpm)
Stroke .....	0.394"	(10 mm)

### MODEL 5CP6251.44101 Direct Drive

Flow .....	5.0 gpm	(19 lpm)
Pressure Range .....	100 to 2000 psi	(7 to 140 bar)
Inlet Pressure Range .....	Flooded to 60 psi	(Flooded to 4 bar)
RPM .....	1725 rpm	(1725 rpm)
Stroke .....	0.472"	(12 mm)

## ELECTRIC HORSEPOWER REQUIREMENTS

MODELS	FLOW		PRESSURE			rpm
			psi 1200	psi 1600	psi 2000	
	U.S. gpm	lpm	bar 85	bar 105	bar 140	
5CP6221.44101	6.0	23	5.0	6.6	8.2	1400
	5.0	19	4.1	5.5	6.8	1208
	4.0	15	3.3	4.4	5.5	966
5CP6241CS.44101	4.0	15	3.3	4.4	5.5	1725
5CP6251.44101	5.0	19	4.1	5.5	6.8	1725

<b>DETERMINING THE PUMP R.P.M.</b>	$\frac{\text{Rated gpm}}{\text{Rated rpm}}$	=	$\frac{\text{"Desired" gpm}}{\text{"Desired" rpm}}$
<b>DETERMINING THE REQUIRED H.P.</b>	$\frac{\text{gpm} \times \text{psi}}{1460}$	=	Electric Brake H. P. Required
<b>DETERMINING MOTOR PULLEY SIZE</b>	$\frac{\text{Motor Pulley O.D.}}{\text{Pump rpm}}$	=	$\frac{\text{Pump Pulley O.D.}}{\text{Motor rpm}}$

See complete Drive Packages [Incls: Pulleys, Belts, Hubs, Key] Tech Bulletin 003. Refer to pump **Service Manual** for repair procedure and additional technical information.

## PARTS LIST

ITEM	P/N	MATL	DESCRIPTION	QTY
5	119049	SS	Screw, HHC, Sems (M8x16)	8
8	46910	AL	Cover, Bearing	2/1
10	76028	FPM	O-Ring, Cover, Bearing - 70D	2/1
11	76236	FPM	Seal, Oil, Crankshaft - 70D	2
15	14480	STL	Bearing, Ball	2
20	48742	TNM	Rod Assy, Connecting	3
25	<b>46928</b>	<b>FCM</b>	Crankshaft, Dual End – 5CP6221.44101 (18mm)	1
	<b>48203</b>	<b>FCM</b>	Crankshaft, Single End – 5CP6241CS.44101 (10mm)	1
	<b>46982</b>	<b>FCM</b>	Crankshaft, Dual End – 5CP6251.44101 (12mm)	1
30	<b>48224</b>	<b>AL</b>	Cover, Blind Bearing – 5CP6241CS.44101	1
31	76142	AL	Adapter, Breather	1
32	76797	BB	Cap, Vented	1
36	76792	SS	Gauge, Sight	1
37	76791	AL	Adapter, Sight	1
38	44428	NBR	Gasket, Flat, Adapter - 80D	1
40	92538	S	Screw, HHC, Sems (M6x16)	4
48	25625	STCP	Plug, Drain (1/4X19BSP)	1
49	30322	FPM	O-Ring, Drain Plug	1
50	46940	AL	Cover, Rear	1
51	76234	FPM	O-Ring, Cover, Rear - 70D	1
53	48617	AL	Crankcase	1
64	46746	CM	Pin, Crosshead	3
65	48458	BBNP	Rod, Plunger	3
70	76838	FPM	Seal, Oil, Crankcase - 70D	3
75	43328	S	Slinger, Barrier	3
88	45697	S	Washer, Keyhole (M18 x 10)	3
90	46841	CC	Plunger (M20x50)	3
98	48394	FPM	Washer, Seal - 90D	3
99	† 48201	SS	Retainer, Plunger w/Stud (M6)	3
100	76748	AL	Retainer, Seal	3
106	76149	ST4	Seal, LPS w/S-Spg	3
110	48552	SS	Manifold, Inlet	1
117	119034	S	Screw, HSH (M8x35)	4
125	76395	ST4	Seal, HPS w/S	3
143	15855	FPM	O-Ring, I.V. Adapter, Rear - 70D	3
150	48212	SS	Adapter, Inlet	3
154	11337	FPM	O-Ring, I.V. Adapter, Front - 75D	3
155	11337	FPM	O-Ring, D.V. Adapter, Rear - 75D	3
157	48211	SS	Adapter, Discharge	3
159	11337	FPM	O-Ring, D.V. Adapter, Front - 75D	3
163	11337	FPM	O-Ring, Seat - 75D	3
164	48216	SS	Seat	6
165	43791	FPM	O-Ring, Seat - 90D	6
166	44038	SS	Valve	6
167	44039	SS	Spring	6
168	44564	PVDF	Retainer, Spring	6
185	48554	SS	Manifold, Discharge	1
186	19085	S	Lockwasher, Split (M12)	6
188	120774	S	Screw, HSH (M12x40)	2
189	89575	S	Screw, HSH (M12x60)	4

Optional Parts And Accessories On Page 4

**Bold print part numbers are unique to a particular pump model.**

[ ] Date of latest production change. † Production parts are different than repair parts.

View Tech Bulletins 002, 003, 024, 036, 043, 053, 056, 074, 077, 083, 088 and 095 for additional information.

MATERIAL CODES (Not Part of Part Number): AL=Aluminum BBNP=Brass/Nickel Plated CC=Ceramic CM=Chrome-moly FCM=Forged Chrome-Moly  
FPM=Fluorocarbon NBR=Medium Nitrile (Buna-N) PVDF=Polyvinylidene Fluoride S=304SS SS=316SS STCP=Steel/Chrome Plated  
STL=Steel TNM=Special High Strength

# EXPLODED VIEW

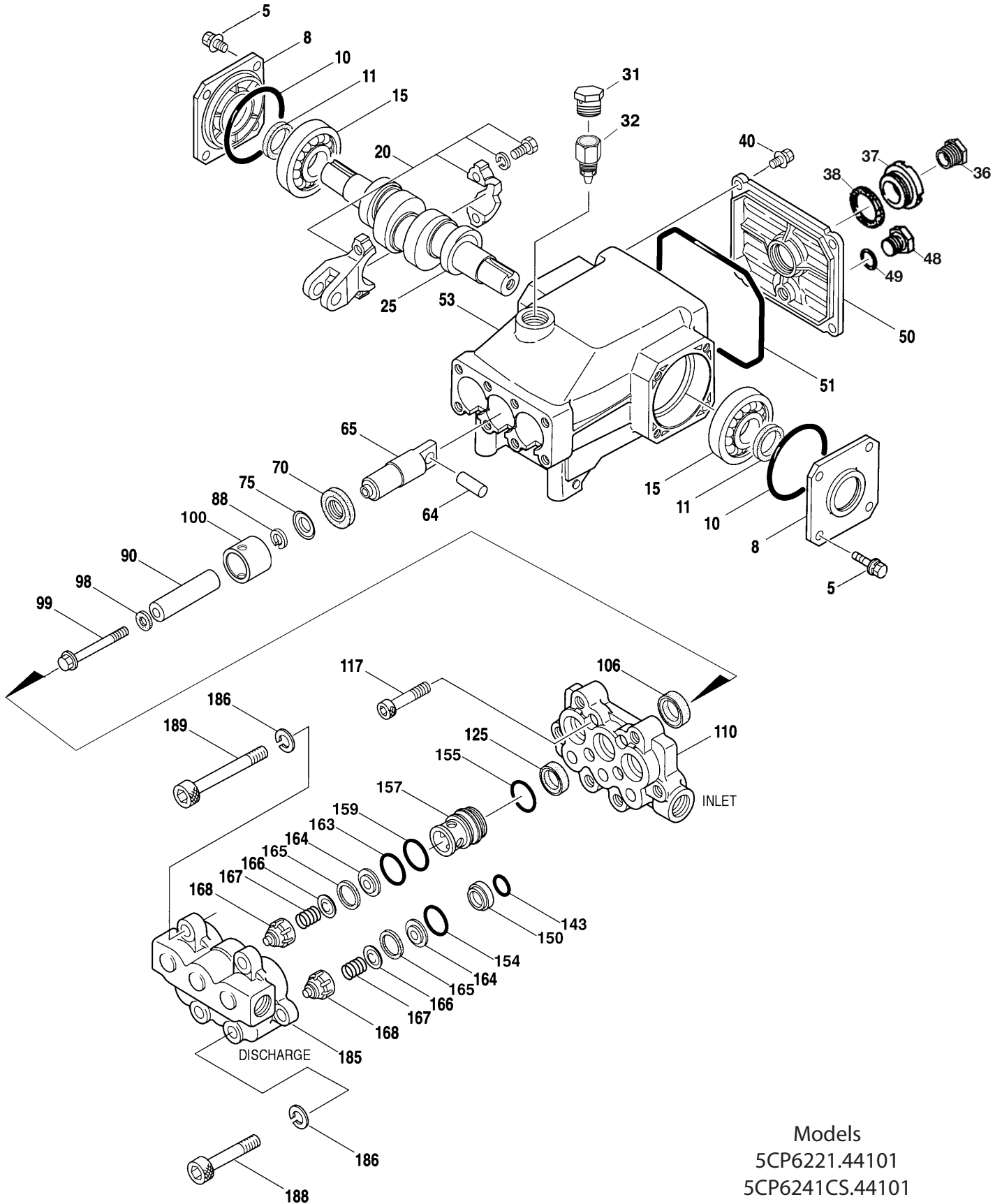

Models  
 5CP6221.44101  
 5CP6241CS.44101  
 5CP6251.44101  
 November 2011

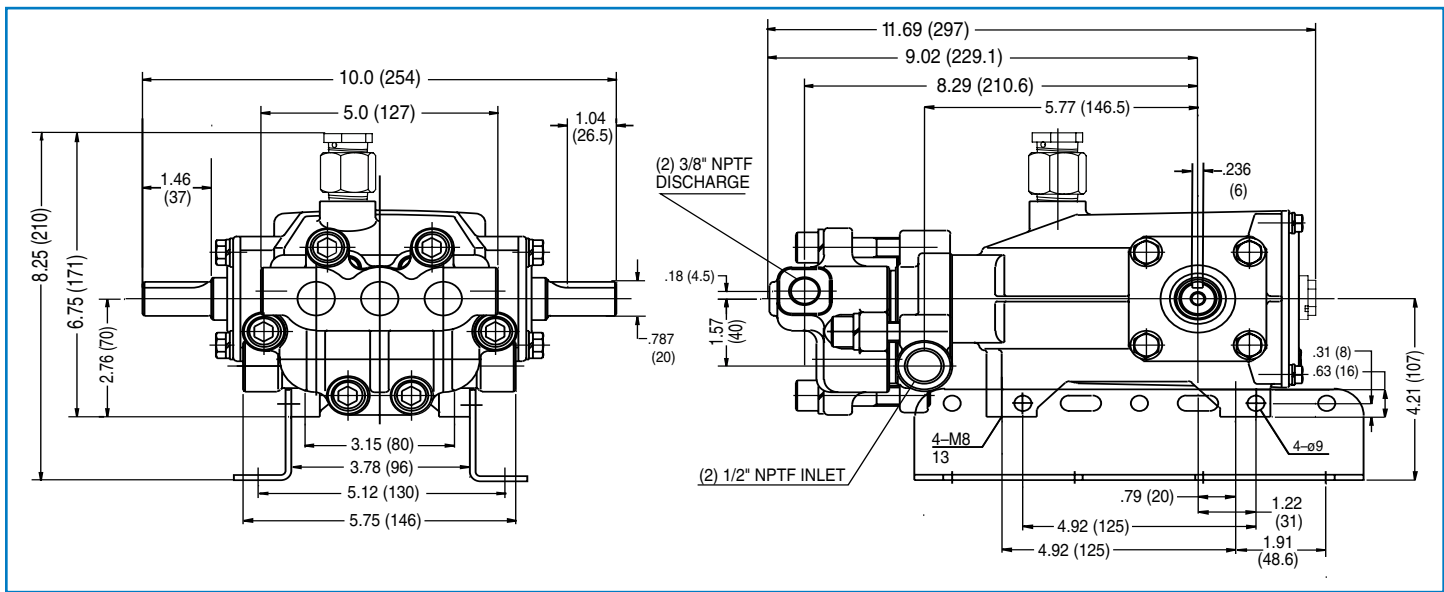

Models 5CP6221.44101, 5CP6241CS.44101, 5CP6251.44101

## OPTIONAL PARTS AND ACCESSORIES

Part Number	Description	QTY
7012.100	Regulator (Primary Pressure Control)	1
7531.0110	Unloader (Primary Pressure Control)	1
7531.1110	Relief Valve (Secondary Pressure Control)	1
99615	Pop-Off Valve (Secondary Pressure Control)	1
6073	Pressure Gauge	1
6030	Accumulator	1
30611	Mounting Rails	1
118672	Shaft Protector	1
30057	Key (M6x6x25)	1
76334	Kit, Oil Indicator (3/8" x 24") See Individual Data Sheet	1
34334	Kit, Oil Drain (3/8" x 24") See Individual Data Sheet	1
76095	Kit, Seal (Includes Items 98, 106, 125, 143, 154, 155, and 159)	1
34362	Kit, Valve (Includes Items 143, 154, 163, 164, 165, 166, 167, and 168)	1
816720.44101	Complete Head	1
30696	Pliers (Reverse)	1
44050	Tool, Sight Gauge Removal	1
6107	Oil, Bottle (21 oz.) ISO 68 Hydraulic	1
6119	Lubricant, Antiseize (1 oz.)	1

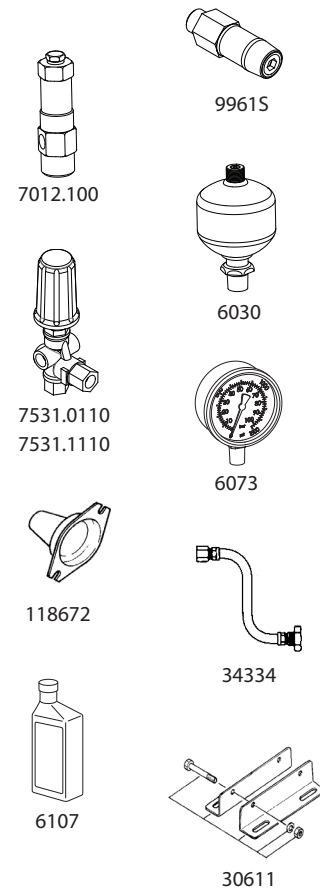

**Demand Genuine Cat Pump Parts And Accessories.**



### CAT PUMPS

1681 - 94TH LANE N.E. MINNEAPOLIS, MN 55449-4324  
 PHONE (763) 780-5440 — FAX (763) 780-2958  
 e-mail: techsupport@catpumps.com  
 www.catpumps.com