

DATA SHEET

HIGH-PRESSURE RELIEF VALVES



Stainless Steel Models: 7034, 7036, 7037



FEATURES

- Provides system pressure setting and protection for single or multiple gun and pump systems.
- Lightweight, compact design quickly and conveniently mounts directly into discharge line.
- Provides back-up protection to primary relief valve for complete pressure relief and maximum pump and system protection.
- 316 Stainless Steel construction for strength and corrosion resistance.
- Standard FPM o-rings with alternative options for temperature and chemical compatibility
 - EPDM – .0220 (7034.0220, 7036.0220, 7037.0220)
 - NBR – .0330 (7034.0330, 7036.0330, 7037.0330)
 - IPFE – .0770 (7034.0770, 7036.0770, 7037.0770)

COMMON SPECIFICATIONS

	U.S.	Metric
Flow Range	0 - 21 gpm	0 - 80 lpm
Maximum Temperatures	195° F	90° C
Inlet Ports (2)	1/2" NPT(F)	1/2" NPT(F)
Discharge Port	1/2" NPT(F)	1/2" NPT(F)
By-Pass Port	1/2" NPT(F)	1/2" NPT(F)
Weight	2.67 lbs.	1.21 kg
Dimensions	8.11 x 3.14 x 1.85"	206 x 80 x 47 mm

SPECIFICATIONS

	U.S. Measure	Metric Measure
7034 (White Spring)		
Pressure Range	400-2200 psi	28-152 bar
Maximum Relief Setting	2420 psi	166 bar
7036 (Blue Spring)		
Pressure Range	800-4000 psi	55-275 bar
Maximum Relief Setting	4400 psi	303 bar
7037 (Black Spring)		
Pressure Range	3000-5700 psi	207-393 bar
Maximum Relief Setting	6270 psi	432 bar

Read all CAUTIONS and WARNINGS before commencing service or operation of any high-pressure system.

SELECTION

This is a stainless steel high pressure relief valve to be used as a secondary pressure relief. Designed for systems with single or multiple guns or pumps, this relief valve should meet the desired system flow (combined nozzle flow rate requirement) and the desired system pressure.

INSTALLATION

The relief valve should be mounted at the discharge manifold between the primary regulating device and the pump and before any other accessories in the system.

Note: The relief valve is a secondary safety device. It does not replace a pressure regulator or unloader.

There are two inlet connections for this relief valve, both are 1/2" NPT(F) sized ports. One is located at the bottom and has an arrow indicating the direction of flow and the word IN engraved into the body. The other inlet port is located on the back side. There is also an arrow indicating the direction of flow engraved into the body. Liquid from the discharge of the manifold goes through either connection.

The discharge connection for this relief valve is a 1/2" NPT(F) sized port and is located on the front side (hex end). There is an arrow and the word OUT engraved into the body indicating the direction of flow.

The by-pass connection of this relief valve is a 1/2" NPT(F) sized port and is located on the side. The word BY PASS is engraved into the body. By-Pass liquid is directed out this port and can be routed to a reservoir (preferred method) or to a drain or to the pump inlet.

OPERATION

The primary function of this relief valve is to relieve system pressure and by-pass pumped liquid in the event the primary valve should fail. If the primary valve fails to by-pass at set system pressure, this secondary relief valve will open and allow the liquid to by-pass.

PRESSURE ADJUSTMENT

Setting the Primary Pressure Regulating Device

1. Setting and adjusting the primary pressure regulating device and relief valve must be done with the system "on".
2. Start the system with the primary pressure regulating device backed off to the lowest pressure setting (counterclockwise direction) and the relief valve set at the highest pressure setting (clockwise direction).
3. Squeeze the trigger and read the pressure on the gauge at the pump.

Note: Do not read the pressure at the gun or nozzle.

4. If more pressure is desired, release the trigger, adjust primary device by turning in a clockwise direction.
5. Squeeze the trigger and read the pressure.
6. Repeat this process until desired system pressure is attained.

Setting the Relief Valve

1. Turn adjusting nuts on the top of the relief valve in a counterclockwise direction in small increments until there is some visible liquid coming out of the by-pass port.
2. Turn adjusting nuts on the top of the relief valve in a clockwise direction until visible liquid stops coming out.
3. Final adjustment for the relief valve should relieve at 200 PSI above the system operating pressure.

TYPICAL RELIEF VALVE INSTALLATION

1. Pressure Gauge
2. Relief Valve
Secondary Safety Device
3. Pressure Regulator
Primary Regulating Device
4. Triplex Plunger Pump

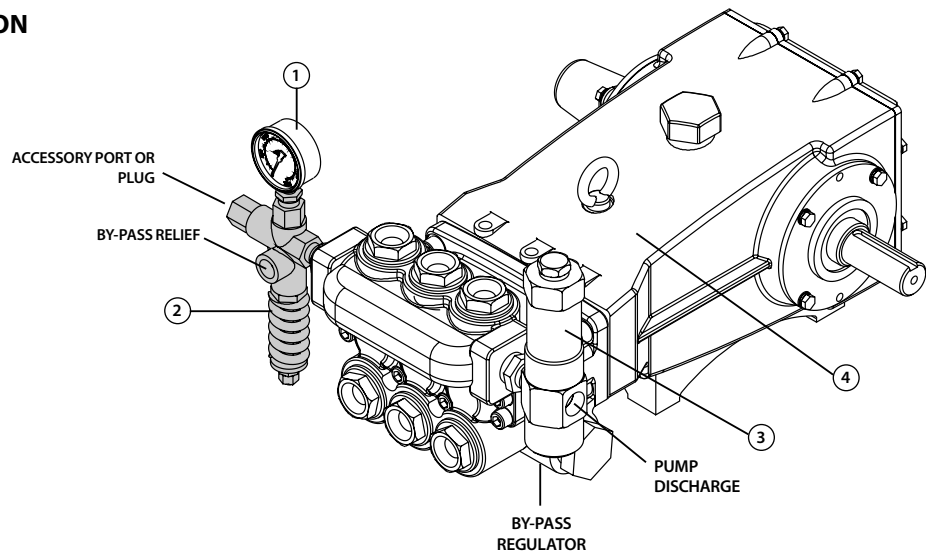

Read all CAUTIONS and WARNINGS before commencing service or operation of any high-pressure system.

SERVICING

Disassembly:

1. Disconnect by-pass and discharge plumbing from relief valve.
2. Remove relief valve from pump and secure in a vise.
3. Remove adjusting nuts, spring retainer and pressure spring from body. Examine pressure spring for fatigue or breaks and replace as needed.
4. Remove one nut on threaded piston stem.
5. Drive out piston pin from piston retainer.
6. Remove piston retainer with o-ring and backup-ring from body. Examine o-ring and backup-ring for cuts or wear and replace as needed.
7. Remove piston stem with o-ring and backup-rings from body. Examine o-ring and backup-rings for cuts or wear and replace as needed.
8. Remove inlet fitting with o-ring, spring and ball. Examine o-ring for cuts or wear and replace as needed. Examine spring for fatigue or breaks and replace as needed.
9. Tap out valve seat with o-ring from the top. Examine o-ring for cuts or wear and replace as needed.

Note: Inspect sealing areas within the internal body of the relief valve for grooves, pitting and wear. If damage is found, replace with new relief valve. If not, proceed with reassembly.

Reassembly:

1. Lubricate and install o-ring onto seat. Press seat into relief valve body from the bottom port with the chamfered surface facing down.
2. Lubricate and install o-ring onto inlet fitting. Apply antiseize lubricant (P/N 6119) onto threads of inlet fitting and body. Place spring into recessed port of inlet fitting and then place ball onto spring. Carefully thread inlet fitting with spring and ball into relief valve body.
3. Lubricate and install one o-ring into groove on piston stem. Place one backup-ring on each side of the o-ring. Lower piston stem into top port until completely seated.
4. Lubricate and install large o-ring onto outer diameter of piston retainer. Lubricate and install small backup-ring and then small o-ring into hole of threaded end of the piston retainer. Apply antiseize lubricant (P/N 6119) onto threads of piston retainer and body. Carefully thread piston retainer into relief valve body.

Note: Ensure that hole in piston stem aligns with slot on top of piston retainer.

5. Press in piston pin through slot in piston retainer and hole in piston stem.
6. Apply Loctite® 609 to threads of one nut and thread onto piston stem. Nut should thread down to last thread on piston stem.

Note: Model 7037 uses 2 lower nuts.

7. Install pressure spring over piston stem, then spring retainer with boss facing down. Thread on hex nut.
8. Reinstall relief valve onto pump.
9. Reconnect by-pass and discharge plumbing to pressure relief valve.
10. Proceed to PRESSURE ADJUSTMENT.

Loctite® is a registered trademark of the Henkel Corporation.

TROUBLESHOOTING

Valve chatters or cycles	<ul style="list-style-type: none">• Valve is improperly set. Repeat adjustment procedure.• Air in system. Check connections.
Valve continually by-passes	<ul style="list-style-type: none">• Seat, ball or piston stem is worn. Replace as needed.• O-Ring seat damaged. Replace as needed.
Leaking out the top of valve	<ul style="list-style-type: none">• O-Rings on piston stem worn or cut. Replace as needed.
Pressure spikes	<ul style="list-style-type: none">• Spring compressed. Do not adjust valve for worn nozzles.• Restricted by-pass or no by-pass.

EXPLODED VIEW

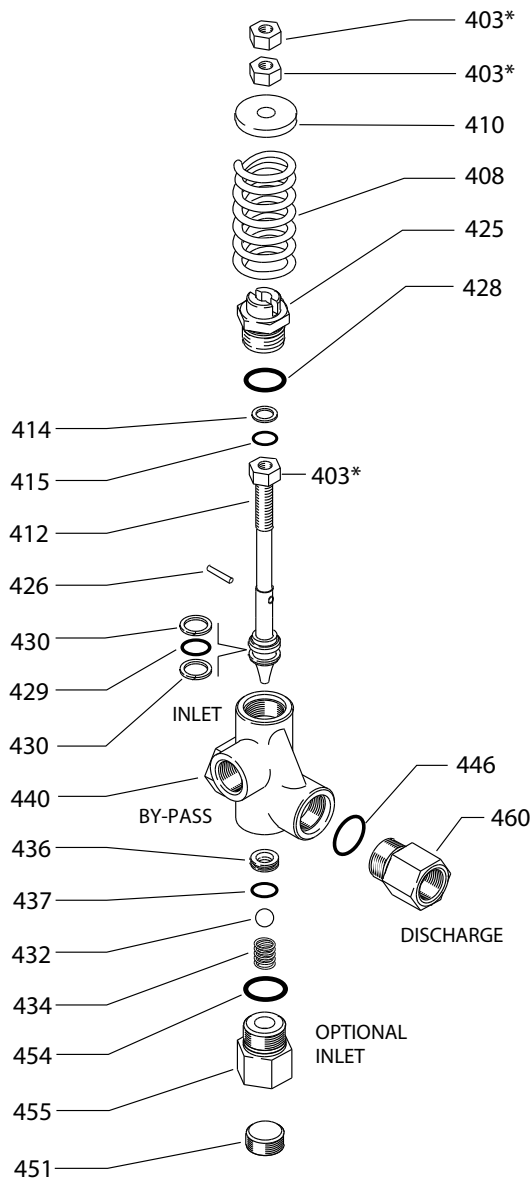

PARTS LIST

ITEM	DESCRIPTION	P/N	MATL	QTY
403	Nut (M10)	30115	S	3
408	Spring, Pressure (Blue-7036)	32324	STL	1
	Spring, Pressure (White-7034)	32323	STL	1
	Spring, Pressure (Black-7037)	32344	STL	1
410	Retainer, Spring	30119	BB	1
412	Stem, Piston	34586	SS	1
414	Back up-Ring, Piston	—	PTFE	1
415	O-Ring, Piston	—	FPM	1
425	Retainer, Piston	30118	SS	1
426	Pin, Piston	32326	S	1
428	O-Ring, Piston Retainer	—	FPM	1
429	O-Ring, Piston	—	FPM	1
430	Back up-Ring, Piston	—	PTFE	2
432	13/32" Ball	30117	SS	1
434	Spring, Ball	30113	SS	1
436	Seat	34509	SS	1
437	O-Ring, Seat	—	FPM	1
440	Body	—	SS	1
446	O-Ring, Fitting	—	FPM	1
451	Plug [1/2" NPT(M)]	34508	S	1
454	O-Ring, Fitting	—	FPM	1
455	Fitting, Inlet [1/2" NPT(F)]	34578	SS	1
460	Fitting, Discharge [1/2" NPT(F)]	34580	SS	1
468	Kit, O-Ring (Standard) <i>(Incls: 414, 415, 428, 429, 430, 437, 446, 454)</i>	30166	FPM	1
	Kit, O-Ring (.0220) <i>(Incls: 414, 415, 428, 429, 430, 437, 446, 454)</i>	76066	EPDM	1
	Kit, O-Ring (.0330) <i>(Incls: 414, 415, 428, 429, 430, 437, 446, 454)</i>	32346	NBR	1
	Kit, O-Ring (.0770) <i>(Incls: 414, 415, 428, 429, 430, 437, 446, 454)</i>	76166	IPFE	1

Bold print part numbers are unique to a particular model

Italics are optional items.

MATERIAL CODES (Not Part of Part Number):

BB=Brass EPDM=Ethylene Propylene Diene Monomer FPM=Fluorocarbon

IPFE=I-Perfluoroelastomer NBR=Medium Nitrile (Buna-N)

PTFE=Pure Polytetrafluoroethylene S=304SS SS=316SS STL=Steel

*Models 7034, 7036 use 1 lower nut and 2 upper nuts.

Model 7037 uses 2 lower nuts and 1 upper nut.

⚠ CAUTIONS AND WARNINGS

All High Pressure Systems require a primary pressure regulating device (i.e. regulator, unloader) and a secondary pressure relief device (i.e. pop-off valve, relief valve). Failure to install such relief devices could result in personal injury or damage to pump or property. Cat Pumps does not assume any liability or responsibility for the operation of a customer's high pressure system.

Read all CAUTIONS and WARNINGS before commencing service or operation of any high pressure system. The CAUTIONS and WARNINGS are included in each service manual and with each Accessory Data sheet. CAUTIONS and WARNINGS can also be viewed online at www.catpumps.com/cautions-warnings or can be requested directly from Cat Pumps.

WARRANTY

View the Limited Warranty on-line at www.catpumps.com/warranty.



CAT PUMPS

1681 - 94TH LANE N.E. MINNEAPOLIS, MN 55449-4324

PHONE (763) 780-5440 — FAX (763) 780-2958

e-mail: techsupport@catpumps.com

www.catpumps.com