



7066

7070, 7076, 7077
(7078 w/o Black Handle)

FEATURES

- Maintains full system pressure while running in idle.
- Offers pump protection against pressure fluctuations and system changes.
- Minimum pressure fluctuations with the alternating use of multiple guns and nozzles.
- Top adjusting handle and locking nut to secure exact pressure setting.
- No external moving parts. Stainless Steel and FPM internal parts for temperature and liquid compatibility.

⚠ WARNING

All systems require both a primary pressure regulating device (i.e., regulator, unloader) and a secondary pressure safety relief device (i.e., pop-off valve, safety valve). Failure to install such relief devices could result in personal injury or damage to the pump or to system components. CAT PUMPS does not assume any liability or responsibility for the operation of a customer's high pressure system.

Stainless Steel Pressure Regulator

Model 7066

SPECIFICATIONS

	U.S. Measure	Metric Measure
MODEL 7066		
Flow Range	1-12 GPM	(3.8-45 L/M)
Pressure Range	3000-5000 PSI	(210-345 BAR)
Maximum Temperature	180°F	(82°C)
Inlet Port	1/2" NPTF	(1/2" NPTF)
By-pass Port	3/4" NPTF	(3/4" NPTF)
Weight	3.8 lbs.	(1.7 kg)
Dimensions	6.7 x 2.5"	(169 x 63.5 mm)

**Models 7070, 7076
7077, 7078**

SPECIFICATIONS

	U.S. Measure	Metric Measure
MODEL 7070, 7078		
Flow Range	1-12 GPM*	(3.8-45 L/M)
Pressure Range	600-1000 PSI*	(40-70 BAR)
*As flow increases, low pressure setting increases (eg. @ 4.0 GPM, 100 PSI minimum, @ 12.0 GPM, 600 PSI minimum).		

MODEL 7076		
Flow Range	1-12 GPM	(3.8-45 L/M)
Pressure Range	800-1500 PSI	(55-105 BAR)

MODEL 7077		
Flow Range	0.5-5.0 GPM	(1.9-19 L/M)
Pressure Range	50-500 PSI	(3.5-35 BAR)

COMMON SPECIFICATIONS

Maximum Temperature	180°F	(82°C)
Inlet Port	1/4" NPTF	(1/4" NPTF)
By-Pass Port	3/8" NPTF	(3/8" NPTF)
Weight	1.2 lbs.	(0.55 kg)
Dimensions	6.2 x 2.5"	(158 x 64 mm)

“Customer confidence is our greatest asset”

SELECTION: This **Pressure Regulator** is designed for systems with **single or multiple** pumps, solenoid (gate) valves, nozzles, standard or “weep” guns.

This regulator maintains established system pressure even when only one of several guns (nozzles) or solenoid (gate) valves is open or a nozzle is clogged, by-passing the unrequired flow.

It returns to established system pressure without delay upon squeezing the trigger gun(s) or opening the solenoid (gate) valve(s).

Select the specific model of regulator to meet both the desired system flow (combined nozzle flow rate requirement) and the desired system pressure.

Exercise caution when matching the system requirements to the regulator flow capacity and pressure rating. Operation below the minimum flow of the regulator causes the regulator to cycle. Operation beyond the rated regulator flow causes premature valve wear, regulator cycling and prevents attaining desired system pressure.

Select a high pressure nozzle sized to provide for both the desired **system flow** and pressure and **regulator by-pass**.

CAUTION

A MINIMUM BY-PASS FLOW of 10% of the REGULATOR RATED FLOW CAPACITY is required for proper regulator performance.

When properly set this regulator protects the pump from pressure extremes associated with obstructions in the discharge line, while maintaining the established system pressure. When no flow is required by the system, the regulator by-passes all the system flow. Pressure is held in the discharge line [between the regulator and gun(s) or solenoid valve(s)] **and at the pump** head ready for a quick return to high pressure operation.

INSTALLATION: This regulator operates properly when mounted in any direction, however, it is preferred to keep the plumbing to a minimum and the pressure adjuster/handle easily accessible. The best location is directly on the pump discharge manifold head. Plumbing to and from the regulator should be at least the size of the regulator ports and flexible, high pressure hose (minimum single wire braid) is required.

The standard **inlet connection** of this regulator is located at the **side**. The regulator can be mounted directly onto the discharge manifold head or in the discharge line using a “T” fitting.

The **by-pass connection** is on the **bottom** of the regulator and can be plumbed in one of the following methods. Note that prolonged by-pass can result in significant heat build-up and frequent by-pass can result in premature wear to the valve. A **MINIMUM BY-PASS OF 10%** is necessary for the regulator to operate properly.

CAUTION

If the entire output is directed through the regulator (zero by-pass) the “cushioning” feature of the by-pass liquid is eliminated and the regulator can malfunction or wear prematurely.

Check the amount of by-pass by disconnecting the by-pass line and measuring the flow into a graduated container.

By-Pass to Reservoir: Ideally the by-pass line should be directed to a reservoir with at least one baffle between the supply line to the pump (from the reservoir) and the return by-pass line (from the regulator into the reservoir). This baffle minimizes turbulence and air bubbles that could enter the pump inlet feed line. **The reservoir capacity should be 6 to 10 times the rated system flow per minute.**

By-Pass to Pump Inlet: Although not recommended, by-pass liquid can be returned to the inlet line of the pump or directly to a pump inlet port (**systems up to 10 GPM**). When using this method an *Inlet Pressure Regulator* is recommended to protect pump inlet Lo-Pressure Seals from pressure spikes in the by-pass line.

NOTE: By-pass line pressure is typically less than 200 PSI. Be certain the *Inlet Pressure Regulator* is **between** the pump inlet and the by-pass line connection. When using this method, a *Thermo Valve* should be installed in the by-pass line to protect the pump from temperature build-up and premature seal failure.

The by-pass line should be **connected to the pump inlet line at a gentle angle of 45° or less and no closer than 10 times the pump inlet port diameter** e.g. 1-1/2" port size = 15" distance from pump inlet port. **Refer to Technical Bulletin 064 for additional information on the size and length of the by-pass line.**

By-Pass to Drain: If the by-pass is limited and infrequent, the by-pass can easily drain to an unpressurized drain line (to the ground).

TYPICAL INSTALLATION

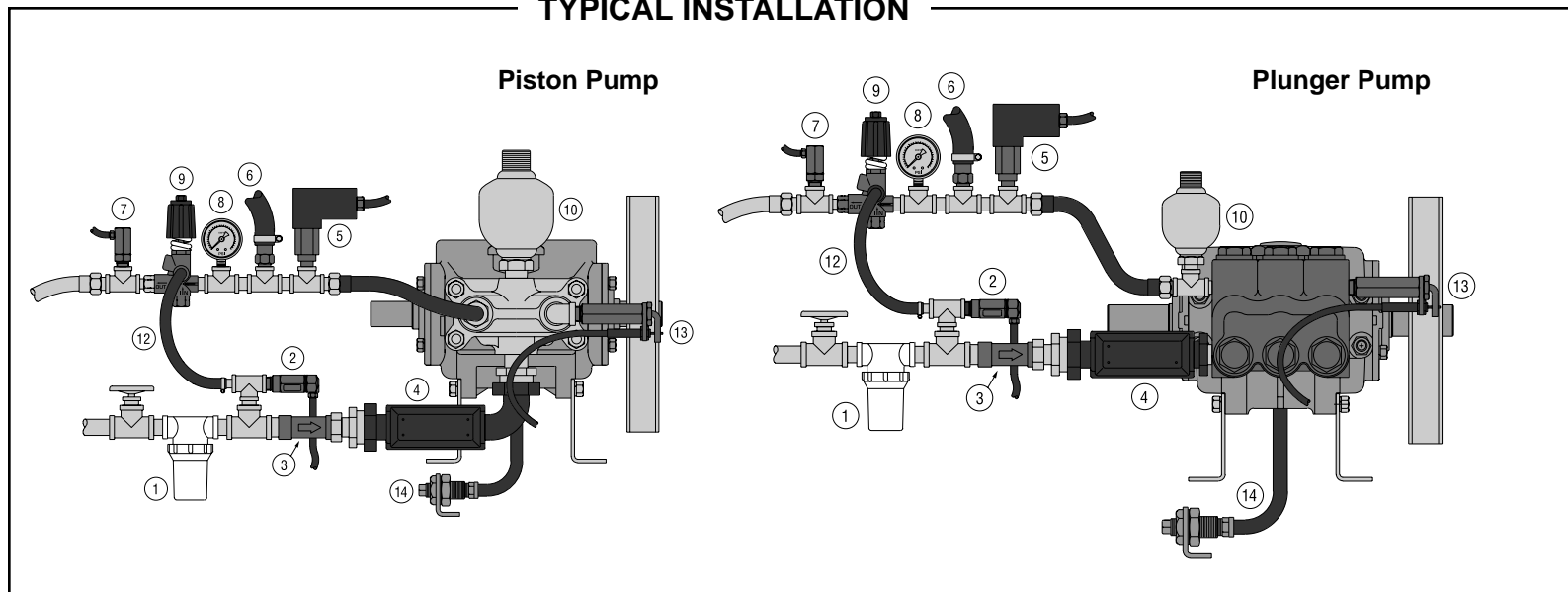

It is recommended that a secondary protective device such as the *CAT PUMP Pop-Off Valve* be installed to assure pump protection should the regulator malfunction. Refer to Troubleshooting for more information on malfunction of regulator.

Preferred mounting of the *Prrrrr-o-lator* (pulsation dampener) is directly **on the Discharge Manifold Head**. When using the *Inlet Pressure Regulator*, mount the *Prrrrr-o-lator* **downstream from the regulator** to assure optimum performance of the regulator.

CAUTION

Oversizing the *Prrrrr-o-lator* may cause delayed response from the regulator.

PRESSURE ADJUSTMENT: Setting and adjusting the regulator must be done with the system “on”. Start the system with the regulator backed off to the lowest pressure setting (**counterclockwise direction**). Squeeze the trigger and read the pressure on the gauge at the pump. **NOTE: Do not read the pressure at the gun or nozzle.** If more pressure is desired, release the trigger, turn pressure handle/adjuster one quarter turn in a **clockwise direction**. Squeeze the trigger and read the pressure. Repeat this process until desired system pressure is attained.

Once the desired system pressure is reached, stop turning the pressure handle/adjuster. Thread locking nut up to pressure handle/adjuster. **NOTE: The locking nut is not set at the factory.**

If desired system pressure cannot be reached, review TROUBLESHOOTING chart.

When servicing existing systems, back locking nut away from pressure handle/adjuster. Follow adjustment procedures as stated above for new regulators.

NOTE: Do not adjust regulator pressure setting to compensate for a worn nozzle. Check the nozzle as part of the regular maintenance and replace if worn.

SERVICE: The Regulator should be serviced on the same schedule as your pump. Replacing the O-rings is generally all that is required. Lubricate the O-rings for ease of installation and replace all O-rings included in the kit. Examine the seating surfaces and replace the seat, ball/valve retainer and replace as required. Check the adjustment spring and Piston Springs and replace as needed. Reset to system pressure as stated in PRESSURE ADJUSTMENT section.

Approximate Pressure Reading at Gauge	Gauge Between Pump/Regulator	Gauge Between Regulator/Gun-Nozz-Valve
System in operation (gun open)	system pressure	system pressure
System in by-pass (all guns, valves closed)	system pressure	system pressure

TROUBLESHOOTING

Cycling	<ul style="list-style-type: none"> ● Too little flow for valve specifications. ● Air in system, poor connections. ● Inlet seals in pump worn. ● O-ring in gun worn.
System will not build up to pressure	<ul style="list-style-type: none"> ● Nozzle worn. ● Improper nozzle size for system specs. ● Foreign material trapped in seat.
Pressure drop	<ul style="list-style-type: none"> ● Nozzles worn. ● Piston and seat in regulator worn. ● Air in system, poor connections. ● Insufficient flow to pump. ● Filter clogged. Check and clean regularly.
Pressure spikes while in by-pass	<ul style="list-style-type: none"> ● Minimum by-pass of 10% not present. ● Excessive pressure adjustment made for worn nozzle. REPLACE NOZZLE. Reset system pressure.
Leakage from regulator vent hole	<ul style="list-style-type: none"> ● O-ring around piston worn. Replace. ● Piston Retainer scored. Replace as needed.

WARRANTY

90 Day Warranty

Refer to complete CAT PUMPS Warranty for further information.

- | | |
|---|----------------------------------|
| 1 Inlet Filter | 8 Pressure Gauge |
| 2 Thermo Valve | 9 Pressure Regulator/Unloader |
| 3 Inlet Pressure Regulator | 10 Pulsation Dampener★ |
| 4 C. A.T. Tube
(Captive Acceleration Tube) | 11 Chemical Injector (Not Shown) |
| 5 Pressure Switch | 12 By-pass Hose |
| 6 Pop-Off Valve | 13 Throttle Controller |
| 7 Quick Start Valve | 14 Oil Drain Kit |

★ Preferred mounting of Pulsation Dampener [Prrrrr-O-Lator] is directly on the discharge manifold of the pump. The preferred mounting of the by-pass hose [when returning to the inlet] is before the Pressure Reducing Valve. If this is not possible, then mount the Prrrrr-O-Lator after the Pressure Unloading Valve to prevent pressure spikes to the pump inlet.

These illustrations show the basic elements for a typical installation of a high pressure piston or plunger pump. **Not all components shown are required for all applications or systems.** Each component presents potential problems that too often are ascribed to a perfectly functioning pump, such as: a clogged strainer, a partially closed shut-off valve, a faulty gauge, or a malfunctioning regulator/unloader. Proper system installation, routine lubrication, monitoring and maintenance of components are your basic guarantees of optimum pump performance. CAT PUMPS does not assume any liability or responsibility for the design or operation of a customer’s high pressure system.

EXPLODED VIEW
Model 7066

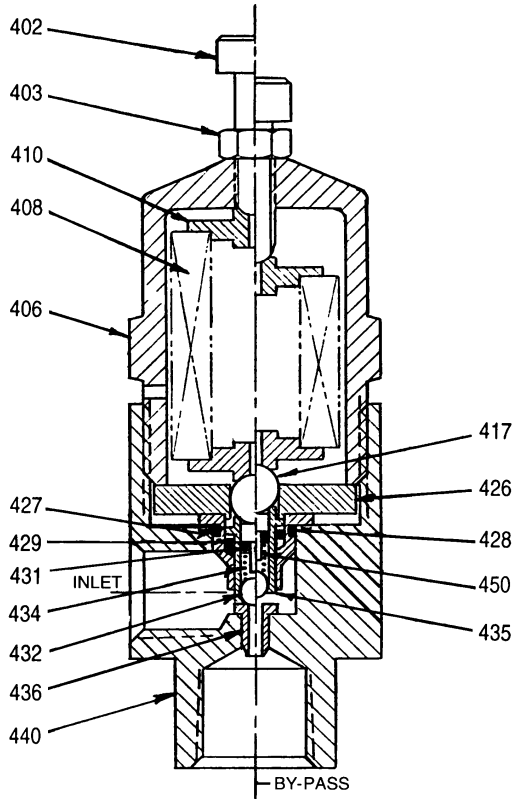

PARTS LIST

ITEM	PN	MATL	DESCRIPTION	QTY
402	30847	SS	Adjuster, Pressure	1
403	30933	S	Nut, Lock	1
406	—	BBCP	Body, Upper	1
408	30935	S	Spring, Pressure	1
410	34289	BB	Retainer, Spring	2
417	34031	SSSS	Ball, Retainer	1
426	34033	BB	Guide, Piston	1
427	33990	SSS	Insert, Piston	1
428	—	FPM	O-Ring	1
429	—	FPM	O-Ring & Back-up-Ring (PTFE)	1
431	—	FPM	O-Ring & Back-up-Ring (PTFE)	1
432	34001	SSSS	Ball, Seat	1
434	34000	S	Spring, Piston	1
435	32110	SS	Piston	1
436	32103	SS	Seat	1
440	33992	S	Body, Lower	1
450	33991	S	Spacer, Ball	1
468	32141	FPM	Kit, O-Ring (Incls: 428,429,431)	1
490	—	—	Mount, Panel (NOT SHOWN)	1

EXPLODED VIEW
Models 7070, 7076, 7077, 7078

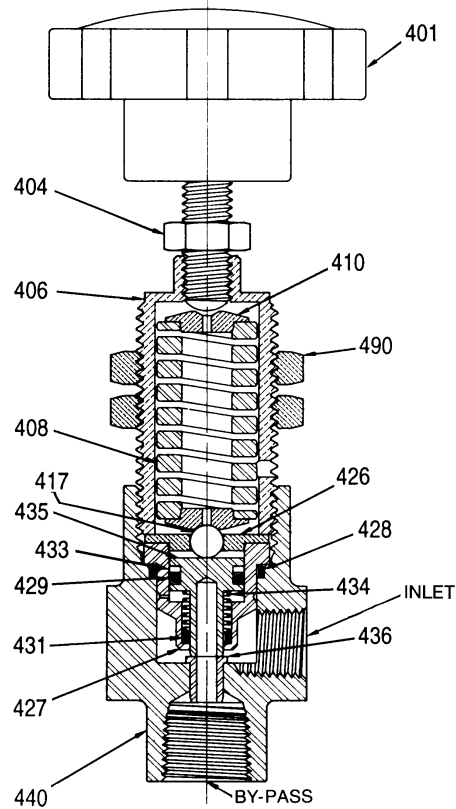

PARTS LIST

ITEM	PN	MATL	DESCRIPTION	QTY
401	33963	NY	Handle, Adjusting w/Screw (7070)	1
	34295	NYSS	Handle, Adjusting w/Screw (7077)	1
	30143	S	Adjuster, Pressure (3/8-16x1, HSH) (7078)	1
404	30933	S	Nut, Lock	1
406	—	BBCP	Body, Upper	1
408	32106	S	Spring Pressure - 1000 PSI (7070)	1
	33206	STL	Spring Pressure - 1500 PSI (7076)	1
	34293	S	Spring Pressure - 500 PSI (7077)	1
410	30141	BB	Retainer, Spring	2
417	34001	SSSS	Ball, Seat	1
426	—	BB	Guide	1
427	—	SS	Insert	1
428	—	FPM	O-Ring	1
429	—	FPM	O-Ring	1
431	—	FPM	O-Ring	1
433	—	PTFE	Back-up-Ring	1
434	34012	S	Spring, Piston	1
435	32109	SS	Piston	1
436	32102	SS	Seat	1
440	—	SS	Body, Lower	1
468	32140	FPM	Kit, O-Ring (Incls: 428,429,431,433)	1
490	34090	STL	Mount, Panel	1

Italics are optional items.

MATERIAL CODES (Not Part of Part Number): BB=Brass BBCP=Brass/Chrome Plated FPM=Fluorocarbon NY=Nylon
PTFE=Pure Polytetrafluoroethylene S=304 Stainless SS=316 Stainless SSS=416SS SSSS=440 Stainless STL=Steel

World Headquarters

CAT PUMPS

1681 - 94th Lane N.E. Minneapolis, MN 55449-4324

Phone (763) 780-5440 — FAX (763) 780-2958

e-mail: techsupport@catpumps.com

www.catpumps.com

International Inquiries

FAX (763) 785-4329

e-mail: intlsales@catpumps.com



The Pumps with Nine Lives

CAT PUMPS (U.K.) LTD.

1 Fleet Business Park, Sandy Lane, Church Crookham, Fleet

Hampshire GU52 8BF, England

Phone Fleet 44 1252-622031 — Fax 44 1252-626655

e-mail: sales@catpumps.co.uk

N.V. CAT PUMPS INTERNATIONAL S.A.

Heiveldekens 6A, 2550 Kontich, Belgium

Phone 32-3-450.71.50 — Fax 32-3-450.71.51

e-mail: cpi@catpumps.be www.catpumps.be

CAT PUMPS DEUTSCHLAND GmbH

Buchwiese 2, D-65510 Idstein, Germany

Phone 49 6126-9303 0 — Fax 49 6126-9303 33

e-mail: catpumps@t-online.de www.catpumps.de