

DATA SHEET

7 FRAME PLUNGER PUMP



Brass Models: 740, 760

Gearbox Models: 740G1, 760G1

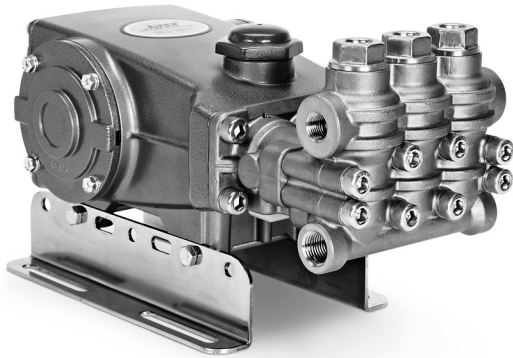

Model 740 shown
(mounting rails sold separately)

FEATURES

- Triplex design delivers high efficiency and low pulsation.
- Durable V-Packings are lubricated and cooled by the liquid being pumped.
- Pre-set Lo-Pressure Seals provide secondary protection against external leaks and require no packing adjustment.
- Special high-density, polished, concentric plungers provide a true wear surface and extended seal life.
- Stacked stainless steel valve design for long life and easy servicing.
- Standard NBR seals with alternative options for temperature and chemical compatibility.

COMMON SPECIFICATIONS

	U.S.	Metric
Inlet Pressure Range	Flooded to 60 psi	Flooded to 4.1 bar
Max. Liquid Temperature (NBR)	160°F	71°C
Alternate seals available for high temperature up to 180°F		
Bore	0.551"	14 mm
Stroke (Model 740)	0.591"	15 mm
Stroke (Model 760)	0.728"	18.5 mm
Crankcase Capacity	25 oz.	0.75 l
Inlet Ports (2)	1/2" NPT(F)	1/2" NPT(F)
Discharge Ports (2)	3/8" NPT(F)	3/8" NPT(F)
Shaft Diameter - Single End	0.945"	24 mm
Weight w/o Gearbox	28.45 lbs.	12.9 kg
Dimensions	14.04 x 8.23 x 6.47"	356.6 x 209 x 164 mm
Dimensions w/Gearbox	14.04 x 10.76 x 6.53"	356.6 x 273 x 166 mm

SPECIFICATIONS	U.S. Measure	Metric Measure
MODEL 740		
Flow	2.9 gpm	11.0 lpm
Pressure Range	100 to 5000 psi	6.9 to 345 bar
Pump RPM*	1750 rpm	1750 rpm
MODEL 760		
Flow	3.6 gpm	13.6 lpm
Pressure Range	100 to 5000 psi	6.9 to 345 bar
Pump RPM*	1750 rpm	1750 rpm
MODEL 740G1		
Flow	2.8 gpm	10.6 lpm
Pressure Range	100 to 5000 psi	6.9 to 345 bar
Pump RPM	1700 rpm	1700 rpm
Engine RPM	3465 rpm	3465 rpm
MODEL 760G1		
Flow	3.5 gpm	15.2 lpm
Pressure Range	100 to 5000 psi	6.9 to 345 bar
Pump RPM	1700 rpm	1700 rpm
Engine RPM	3465 rpm	3465 rpm

*Pump minimum is 100 RPM.
See Gearbox Data Sheet for additional information.

ALTERNATIVE SEAL CONFIGURATION

MATERIAL	SUFFIX CODE	MAXIMUM TEMPERATURE
NBR	—	160° F (71° C)
FPM	.0110	180° F (82° C)
HT	.3000	180° F (82° C)
STHT	.3400	180° F (82° C)

See Reference Document 99REF017 for inlet conditions and RPM at high temperature.

DETERMINING THE PUMP R.P.M.	Rated gpm	=	"Desired" gpm
	Rated rpm	=	"Desired" rpm
DETERMINING THE REQUIRED H.P.	Hp (Electric Brake)	=	$\frac{\text{gpm} \times \text{psi}}{1460}$
	DETERMINING MOTOR PULLEY SIZE	$\frac{\text{Motor Pulley O.D.}}{\text{Pump rpm}}$	= $\frac{\text{Pump Pulley O.D.}}{\text{Motor rpm}}$

Refer to pump **Service Manual** for repair procedure and additional technical information.

PARTS LIST

ITEM	P/N	MATL	DESCRIPTION	QTY
2	30067	STL	Key (M8x7.5x25)	1
5	125824	STCP R	Screw, HHC Sems (M6x16)	8/4
8	133571	ALE	Cover, Bearing (See Tech Bulletin 118, 123)	1
9	815280	FBR	Shim, Split, 2 Pc.	1
10	12393	NBR	O-Ring, Bearing Cover	2/1
11	43222	NBR	Seal, Oil, Crankshaft - 70D	1/0
15	43221	STL	Bearing, Roller	2
20	48863	TNM	Rod, Connecting	3
25	44591	FCM	Crankshaft, Single End (M15 w/34 mm extension) (Models 740 and 740G1)	1
	44947	FCM	Crankshaft, Single End (M18.5 w/34 mm extension) (Models 760 and 760G1)	1
30	133572	ALE	Cover, Blind Bearing (See Tech Bulletin 118, 123)	1
31	828710	PE	Protector, Oil Cap w/Foam Gasket	1
32	44666	RTP	Cap, Oil Filler, Domed	1
33	14177	NBR	O-Ring, Oil Filler Cap - 70D	1
37	92241	—	Gauge, Oil, Bubble w/Gasket - 80D	1
38	44428	NBR	Gasket, Flat, Oil Gauge - 80D	1
40	125824	STCP R	Screw, HHC Sems (M6x16)	4
48	25625	STCP	Plug, Drain (1/4"x19BSP)	1
49	23170	NBR	O-Ring, Drain Plug - 70D	1
50	133569	ALE	Cover, Rear (See Tech Bulletin 118, 123)	1
51	14047	NBR	O-Ring, Rear Cover - 70D	1
53	133593	ALE	Crankcase w/Guide Pins (See Tech Bulletin 118, 123)	1
54	27488	S	Pin, Guide	2
56	43240	POP	Pan, Oil	1
64	43237	CM	Pin, Crosshead	3
65	49892	SZZ	Rod, Plunger	3
69	126589	STCP R	Washer, Oil Seal	3
70	43228	NBR	Seal, Oil, Crankcase	3
75	43328	S	Slinger, Barrier	3
88	45697	S	Washer, Keyhole (M18x10)	3
90	45890	CC	Plunger (M14x72)	3
95	126558	STCP R	Stud, Plunger Retainer (M6x64.5)	3
96	43235	PTFE	Back-up-Ring, Plunger Retainer	3
97	17399	NBR	O-Ring, Plunger Retainer - 80D	3
	14160	FPM	O-Ring, Plunger Retainer - 80D	3
98	45891	CU	Gasket, Plunger Retainer	3
99	46504	S	Retainer, Plunger (M6)	3
100	45689	PVDF	Retainer, Seal, 2-Pc (See Tech Bulletin 105)	3
101	43571	—	Wick, Long Tab	3
106	45188	NBR	Seal, LPS w/S-Spg	3
	704649	ST4	Seal, LPS w/NIH-Spg	3
110	49797	BB	Manifold, Inlet	1
112	11343	NBR	O-Ring, Inlet Manifold - 70D	3
	14186	FPM	O-Ring, Inlet Manifold - 70D	3
117	49679	S	Screw, HSH (M10x35)	4
118	49680	S	Washer	4
121	14200	NBR	O-Ring, V-Packing Spacer - 70D	3
	11719	FPM	O-Ring, V-Packing Spacer	3
122	49840	PTFE	Back-up-Ring, V-Packing Spacer	3
123	49839	NBR	O-Ring, V-Packing Spacer - 90D	3
	11686	FPM	O-Ring, V-Packing Spacer - 80D	3
124	49838	BB	Spacer, V-Packing	3
126	45896	BB	Adapter, Female	3
127	45895	SNG	V-Packing	9
	704666	ST4	V-Packing	9
128	46567	BB	Adapter, Male	3
159	49861	PTFE	Back-up-Ring, Inlet Valve Seat	3
160	11346	NBR	O-Ring, Inlet Valve Seat - 70D	3
	11376	FPM	O-Ring, Inlet Valve Seat - 70D	3
161	49846	S	Seat, Inlet	3
162	49844	PTFE	Back-up-Ring, Discharge Valve Seat	3
163	49845	NBR	O-Ring, Discharge Valve Seat - 70D	3
	49894	FPM	O-Ring, Discharge Valve Seat - 70D	3
164	49843	S	Seat, Discharge	3
165	49847	PVDF	Retainer, Spring, Inlet	3
166	46562	S	Valve	6
167	43750	S	Spring	6
168	44565	PVDF	Retainer, Spring, Discharge	3
172	49382	NBR	O-Ring, Valve Plug - 90D	3
	49897	FPM	O-Ring, Valve Plug - 90D	3
173	49850	PTFB	Back-up-Ring, Valve Plug	3
174	49849	BB	Plug, Valve	3
185	49798	BB	Head, Manifold (M10)	1
188	49852	S	Screw, HSH (M10x65)	8
255	30243	STZP	Mount, Direct	1
260	30645	STZP R	Mount, Rail, Assy (2.95 x 11.81)	1
	30611	STZP R	Mount, Rail, Assy (2.09 x 9.45)	1
265	30660	—	Mount Assy (Incls: 30645, 33000, 30206, 43256, 30067)	1
269	30206	F	Pulley (10") AB (See Tech Bulletin 003)	1
274	33000	STL	Hub (M24), H Series (See Tech Bulletin 003)	1
283	34334	—	Kit, Oil Drain (3/8"x 24") (See individual Data Sheet)	1

EXPLODED VIEW

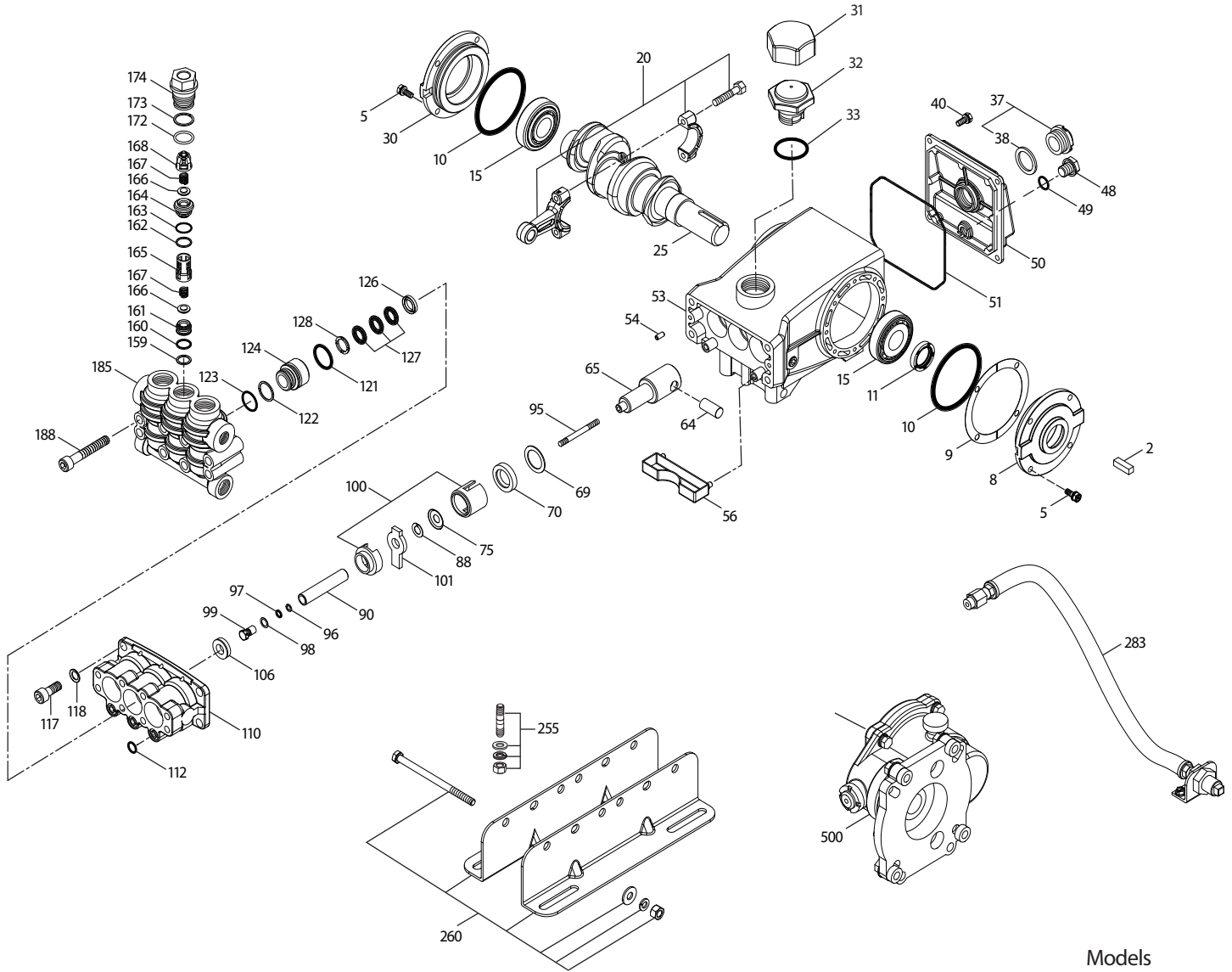

Models
740, 740G1
760, 760G1
May 2019

ITEM	P/N	MATL	DESCRIPTION	QTY
—	76334	—	Kit, Oil Indicator (3/8"x 24") (See individual Data Sheet)	1
299	818537	FBB	Head, Complete w/NBR Seals and O-Rings	1
300	76079	NBR	Kit, Seal (Incls: 97,101,106,112,121,122,123,127) (Standard)	1
—	76032	FPM	Kit, Seal (Incls: 97,101,106,112,121,122,123,127) (.0110)	1
—	76578	NBR*	Kit, Seal (Incls: 97,101,106,112,121,122,123,127) (.3400)	1
310	76081	NBR	Kit, Valve (Incls: 159,160,161,162,163,164,165,166,167,168,172,173) (Standard) (.3400)	1
—	76034	FPM	Kit, Valve (Incls: 159,160,161,162,163,164,165,166,167,168,172,173) (.0110)	1
350	30696	STZP	Pliers, Reverse	1
500	8071	—	Gearbox, 1" (See 8051 Data Sheet) (740G1, 760G1)	1
—	6107	—	Oil, Bottle (21 oz.) ISO 68 Hydraulic (Fill to specified crankcase capacity prior to start-up)	1-2
—	6110	—	Lube, Gear (16oz.) 80-90W (To fill 8071 gearbox)	1

Bold print numbers are unique to a particular pump model. *Italics are optional items.* [] Date of latest production change.

R Components comply with RoHS Directive. Refer to Tech Bulletins 024, 036, 043, 061, 064, 067, 074, 083, 105, 118 and 123 for additional information.

MATERIAL CODES (Not Part of Part Number): AL=Aluminum ALE=Aluminum Epoxy BB=Brass CC=Ceramic CM=Chrome-Moly CU=Copper F=Cast Iron

FBB=Forged Brass FBR=Fiber FCM=Forged Chrome-moly FPM=Fluorocarbon NBR=Medium Nitrile (Buna-N) PE=Polyethylene POP=Polypropylene

PTFB=Polytetrafluoroethylene w/60% Bronze PTFE=Pure Polytetrafluoroethylene PVDF=Polyvinylidene RTP=Reinforced Composite

S=304SS SNG=Special Blend (Buna) ST4=Special PTFE 4 STL=Steel STCP=Steel/Chrome Plated

STZP=Steel/Zinc Plated SZZ=3044SS/Zamak TNM=Special High Strength

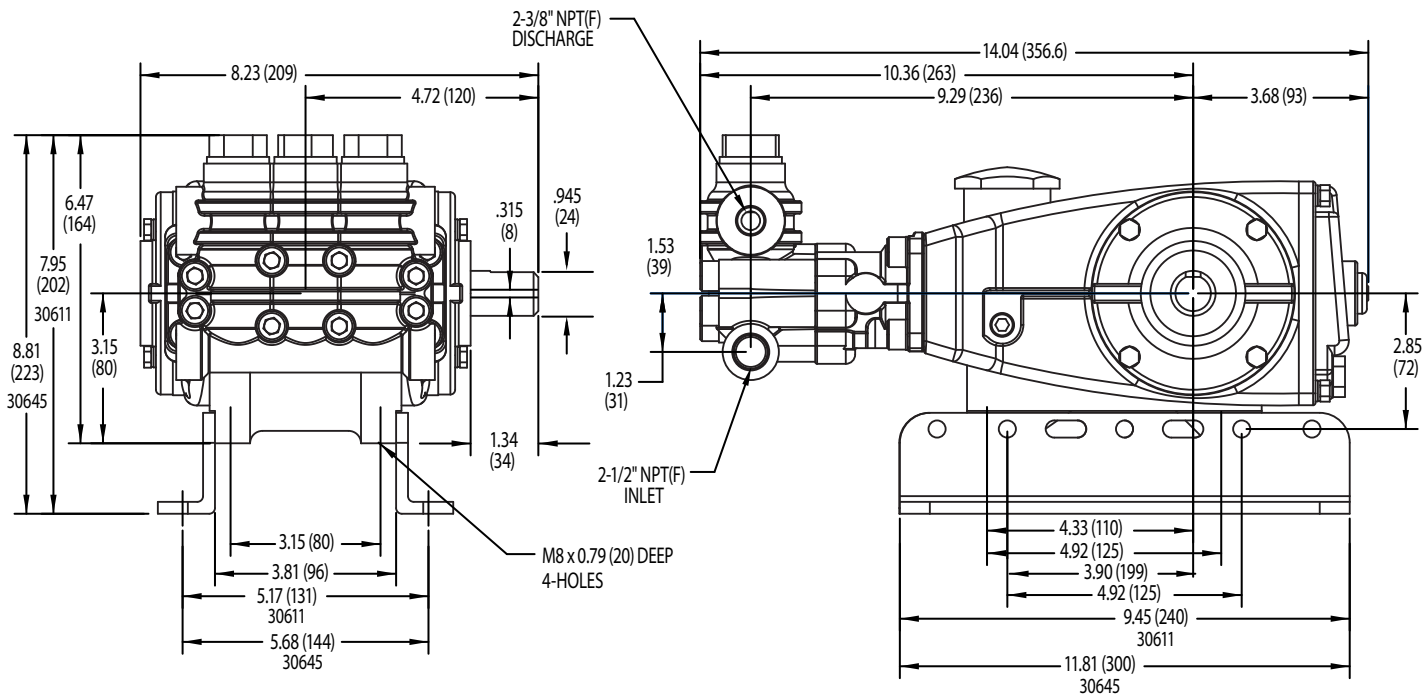

Models 740, 760

⚠ CAUTIONS AND WARNINGS

All High Pressure Systems require a primary pressure regulating device (i.e. regulator, unloader) and a secondary pressure relief device (i.e. pop-off valve, relief valve). Failure to install such relief devices could result in personal injury or damage to pump or property. Cat Pumps does not assume any liability or responsibility for the operation of a customer's high pressure system.

Read all CAUTIONS and WARNINGS before commencing service or operation of any high pressure system. The CAUTIONS and WARNINGS are included in each service manual and with each Accessory Data sheet. CAUTIONS and WARNINGS can also be viewed online at www.catpumps.com/cautions-warnings or can be requested directly from Cat Pumps.

WARRANTY

View the Limited Warranty on-line at www.catpumps.com/warranty.