

DATA SHEET

VERTICAL MULTISTAGE PUMP



Stainless Steel
Model:

832K4S10T3F



SPECIFICATIONS

Size

Suction 150# ANSI raised face 2.50"

Discharge 150# ANSI raised face 2.50"

HP 15 HP

RPM 3450 RPM

Liquid handled

Type of liquid Clean water (for other clean liquids, consult factory)

Temperature 5° to +248°F (-15° to 120°C)

Working pressure 440 psi (30 bar) max.

Materials

Impeller AISI 304

Intermediate casing AISI 304

Bottom casing Cast Iron

Casing cover Cast Iron

Outer casing AISI 304

Shaft AISI 316

Liner ring PTFE/AISI 316

Motor bracket Cast Iron

Base Cast Iron

Pump Bearing Sealed ball bearing/tungsten carbide

Mechanical seal Silicon/Carbide/Carbon/FPM

Motor

Type NEMA 215TC frame

Speed 60 Hz, 3450 RPM (2 poles)

Three Phase 208-230/460V

Direction of Rotation Clockwise when viewed from motor end

Test standard ISO 9906 annex A

Weight

Pump 176 lbs

Motor 143 lbs

NOTE: See PN 99SVM001 for complete operating instructions, installation and maintenance manual information.

PERFORMANCE CURVE – 3450 RPM

185 gpm, 340 Ft/Hd

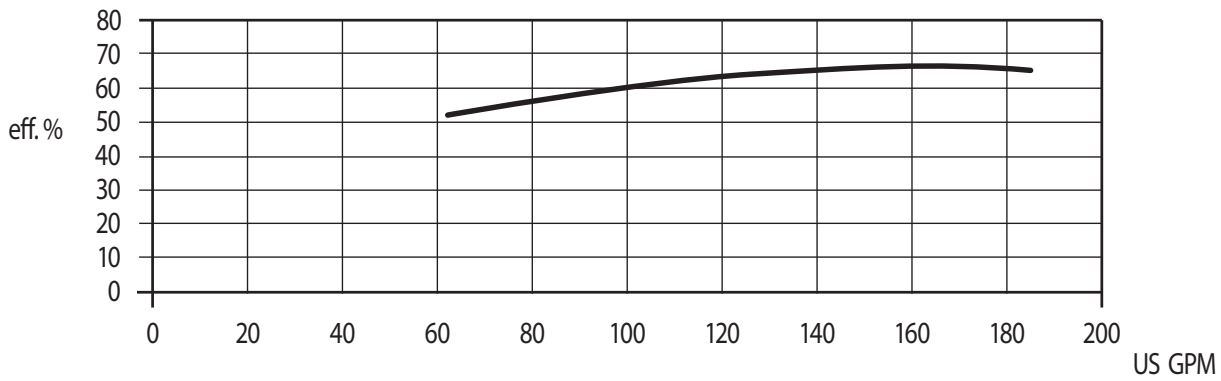
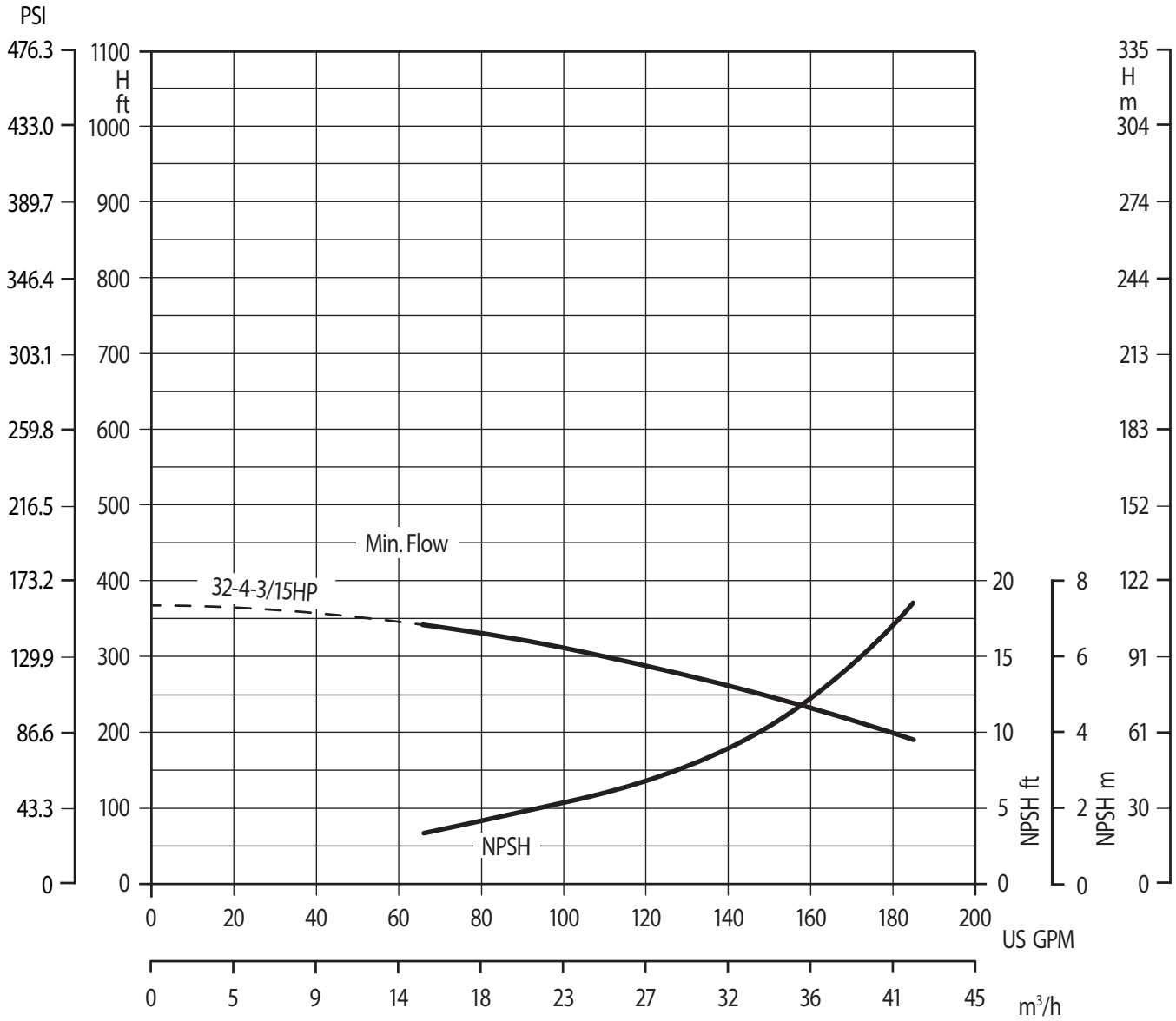

EXPLODED VIEW

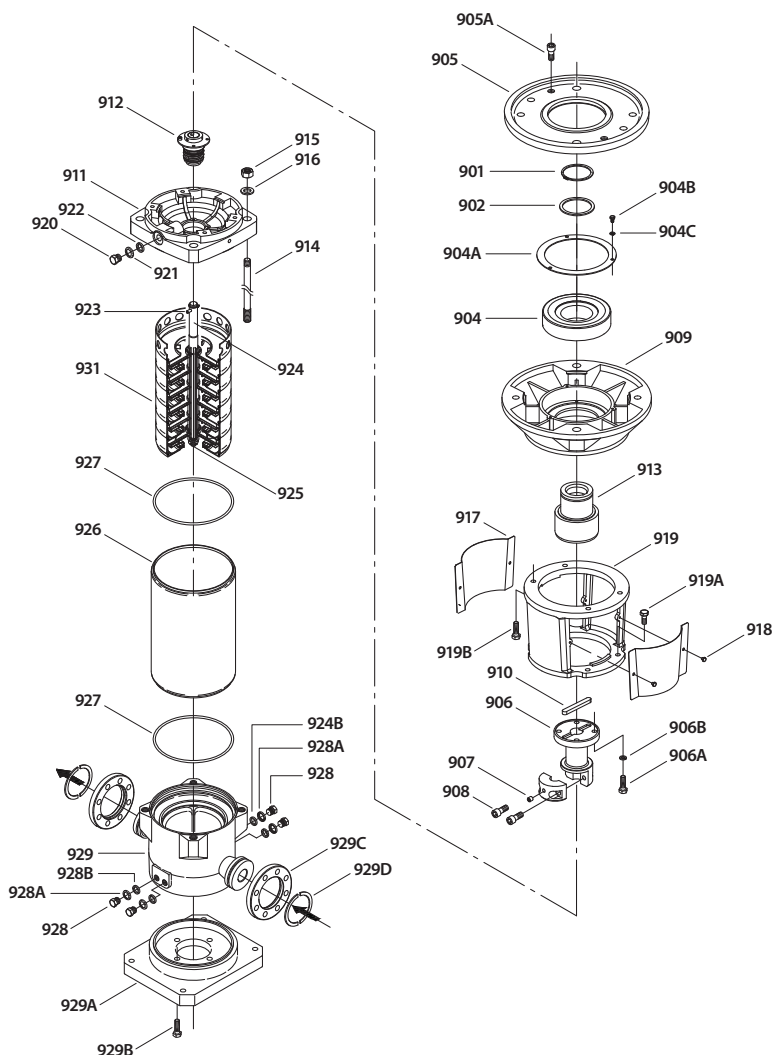

900 Motor not Shown

PARTS LIST

PART					PART				
ITEM	NUMBER	MATL	DESCRIPTION	QTY	ITEM	NUMBER	MATL	DESCRIPTION	QTY
900	—	—	Motor, Electric (not shown)	1	919B	—	STZP	Screws, Bearing Housing	4
901	—	STL	Ring, Snap, C-type for coupler	1	920	—	SS	Plug, Vent	1
902	—	STL	Spacer	1	921	—	S	Washer, Vent Plug	1
904	—	STL	Bearing, Ball	1	922	—	FPM	O-Ring, Vent Plug	1
904A	—	S	Holder, Bearing	1	923	—	STL	Pin, Shaft	1
904B	—	STZP	Screws, Bearing Holder	3	924	—	SS	Shaft	1
904C	—	STZP	Washers, Spring, Bearing holder	3	925	—	S	Nut, Impeller	1
905	—	F	Liner, Motor	1	926	—	SS	Casting, Outer	1
905A	—	STZP	Screws, Motor Liner	4	927	—	FPM	O-Ring, Outer Casing	2
906	—	STL	Coupling, Lower	1	928	—	SS	Plug, Drain	4
906A	—	STZP	Screws, Lower Coupling	4	928A	—	SS	Washer, Drain Plug	4
906B	—	STZP	Washer, Spring, Lower Coupling	4	928B	—	FPM	O-Ring, Drain Plug	4
907	—	STL	Screw, Set	1	929	—	SS	Casing, Bottom	1
908	—	STZP	Screws, Coupler	2	929A	—	F	Base	1
909	—	F	Housing, Bearing	1	929B	—	STZP	Screws, Base	4
910	—	STL	Key	1	929C	—	STL	Flange, Pump	2
911	—	F+S	Cover, Casing	1	929D	—	STL	Ring, Adjusting	2
912	—	FSC	Seal, Mechanical	1	930	899409		<i>Kit, Seal (Includes mechanical seal and 2 outer casing O-Rings)</i>	1
913	—	STL	Coupling, Upper	1	931	—		<i>Kit, Hydraulic Includes: Hydraulic Assembly Upper and lower casing o-rings Pump shaft key Pumps coupling snap ring Mechanical seal with o-rings</i>	1
914	—	STZP	Rods, Tie	4					
915	—	STZP	Nuts, Tie Rod	4					
916	—	STZP	Washers, Tie Rod	4					
917	—	S	Guard, Coupling	2					
918	—	S	Screws, Coupling Guard	2					
919	—	F	Bracket, Motor	1					
919A	—	S	Screws, Motor Bracket	4					

Italics are optional items

Material Codes (Not part of part number): F = Cast Iron, FPM = Fluorocarbon, FSC = FPM w/Silicon Carbide, S = 304 Stainless Steel, SS = 316 Stainless Steel, STL = Steel, STZP = Steel/Zinc Plated

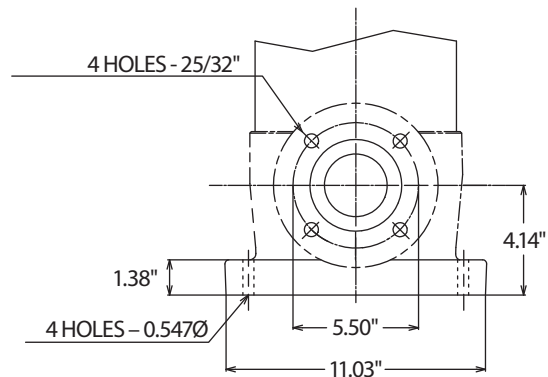
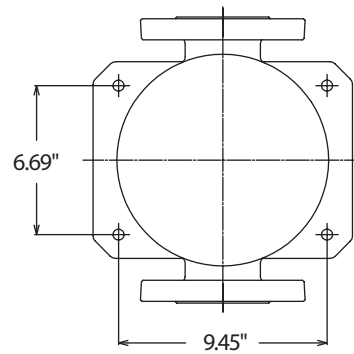
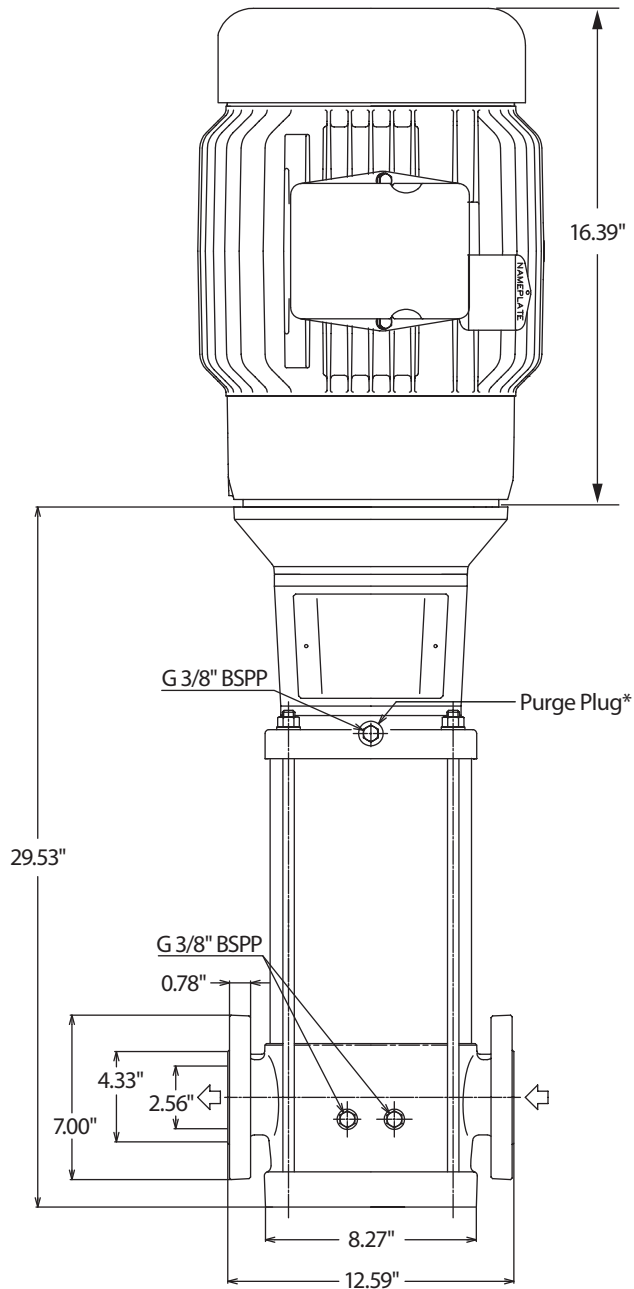

*** All air must be purged out before operation to prevent seal damage.**

⚠ CAUTIONS AND WARNINGS

All High-Pressure Systems require a primary pressure regulating device (i.e. regulator, unloader) and a secondary pressure relief device (i.e. pop-off valve, relief valve). Failure to install such relief devices could result in personal injury or damage to pump or property. Cat Pumps does not assume any liability or responsibility for the operation of a customer's high pressure system.

Read all CAUTIONS and WARNINGS before commencing service or operation of any high pressure system. The CAUTIONS and WARNINGS are included in each service manual and with each Accessory Data sheet. CAUTIONS and WARNINGS can also be viewed online at www.catpumps.com/cautions-warnings or can be requested directly from Cat Pumps.

WARRANTY

View the Limited Warranty on-line at www.catpumps.com/warranty.



CAT PUMPS

1681 - 94th Lane N.E. Minneapolis, MN 55449-4324

Phone (763) 780-5440 · Fax (763) 780-2958 · e-mail: techsupport@catpumps.com · www.catpumps.com