

DATA SHEET

VERTICAL MULTISTAGE PUMP



**Stainless Steel
Model:**

85K16S8T3F



SPECIFICATIONS

Size

Suction 300# ANSI raised face 1.25"

Discharge 300# ANSI raised face 1.25"

HP 7.5 HP

RPM 3450 RPM

Liquid handled

Type of liquid Clean water (for other clean liquids, consult Cat Pumps)

Temperature -22° to +248°F (-30° to 120°C)

Working pressure 360 psi (25 bar) max.

Materials

Impeller AISI 304

Intermediate casing AISI 304

Bottom casing AISI 304

Casing cover AISI 304

Outer casing AISI 304

Shaft AISI 304

Liner ring AISI 304

Motor bracket Cast iron

Base Die Cast Aluminum

Lower Pump Bearings Tungsten carbide

Mechanical seal Silicon/Carbide/Carbon/FPM

Motor

Type NEMA 213TC frame, TEFC

Speed 60 Hz, 3450 RPM (2 poles)

Three Phase 208-230/460V

Direction of Rotation Clockwise when viewed from motor end

Weight

Pump 59.6 lbs

Motor 96.0 lbs

NOTE: See PN 99SVM001 for complete operating instructions, installation and maintenance manual information.

PERFORMANCE CURVE – 3450 RPM

41 gpm, 700 Ft/Hd

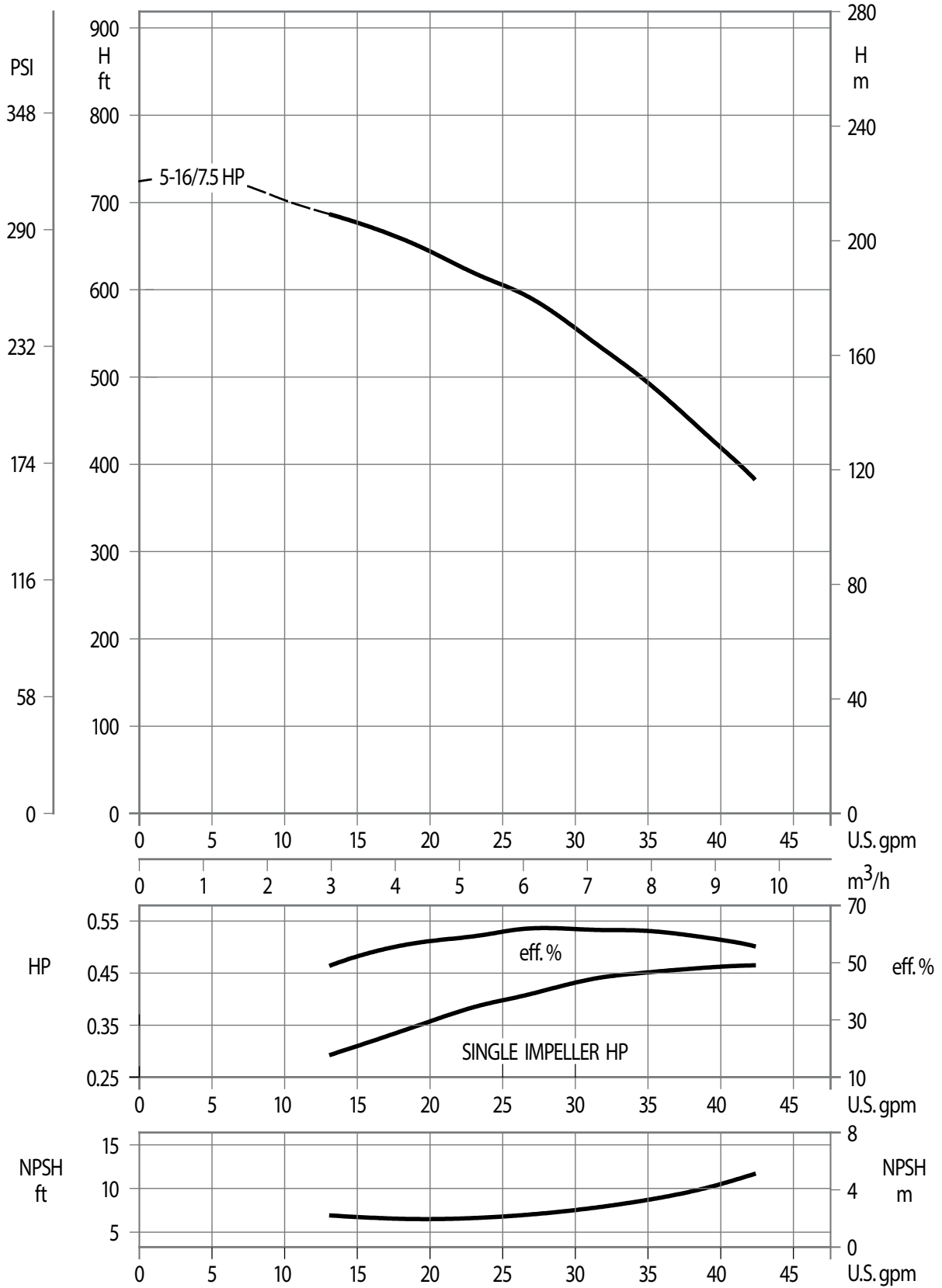

EXPLODED VIEW

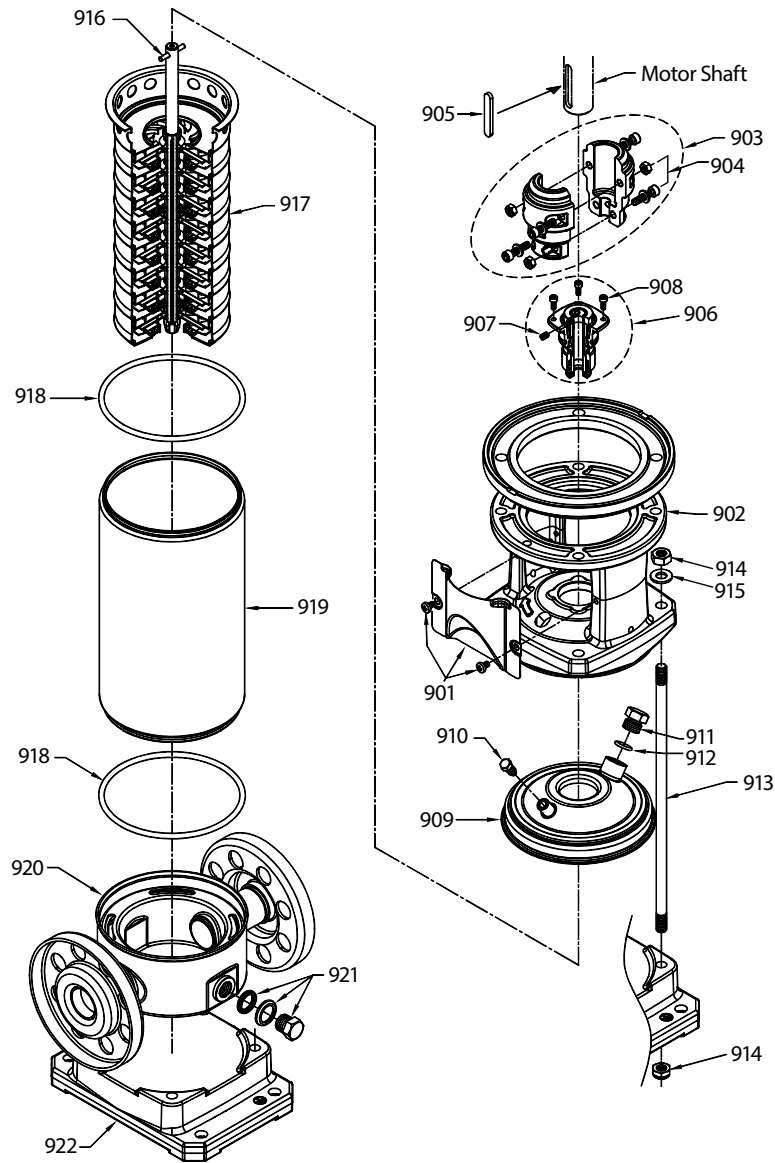

PARTS LIST

ITEM	PART NUMBER	MATL	DESCRIPTION	QTY
900	—	—	Motor, Electric (not shown)	1
901	—	S	Assy, Coupler Guard	2
902	—	F	Bracket, Motor	1
903	—	AL	Coupling (2 piece)	1
904	—	STL	Hardware, Coupling (M6)	4
905	—	S	Key, Adjuster	1
906	—	FSC	Seal, Mechanical	1
907	—	STL	Screw, Set	1
908	—	STZP	Screws, Mechanical Seal Seat	4
909	—	S	Cover, Casing	1
910	—	S	Plug, Priming	1
911	—	S	Plug	1
912	—	FPM	O-Rings, Plug	1

ITEM	PART NUMBER	MATL	DESCRIPTION	QTY
913	—	STZP	Rods, Tie	4
914	—	STZP	Nuts, Tie Rod	4
915	—	STZP	Washer, Tie Rod	4
916	—	STL	Pin, Shaft	1
917	—	S	Assy, Hydraulic	1
918	—	FPM	O-Ring, Outer Casing	2
919	—	S	Casing, Outer	1
920	—	S	Casing, Bottom	1
921	—	S	Assy, Plug, Drain	2
922	—	AL	Base	1
923	—	—	Kit, Seal (Includes: 906, 918)	1
924	—	—	Kit, Hydraulic (Includes: 905, 906, 917, 918)	1

Note: Contact Cat Pumps for part numbers for seals or hydraulic kits.

Italics are optional items

Material Codes (Not part of part number):

AL = Aluminum, F = Cast Iron, FPM = Fluorocarbon, FSC = FPM w/Silicon Carbide, S = 304 Stainless Steel, STL = Steel, STZP = Steel/Zinc Plated

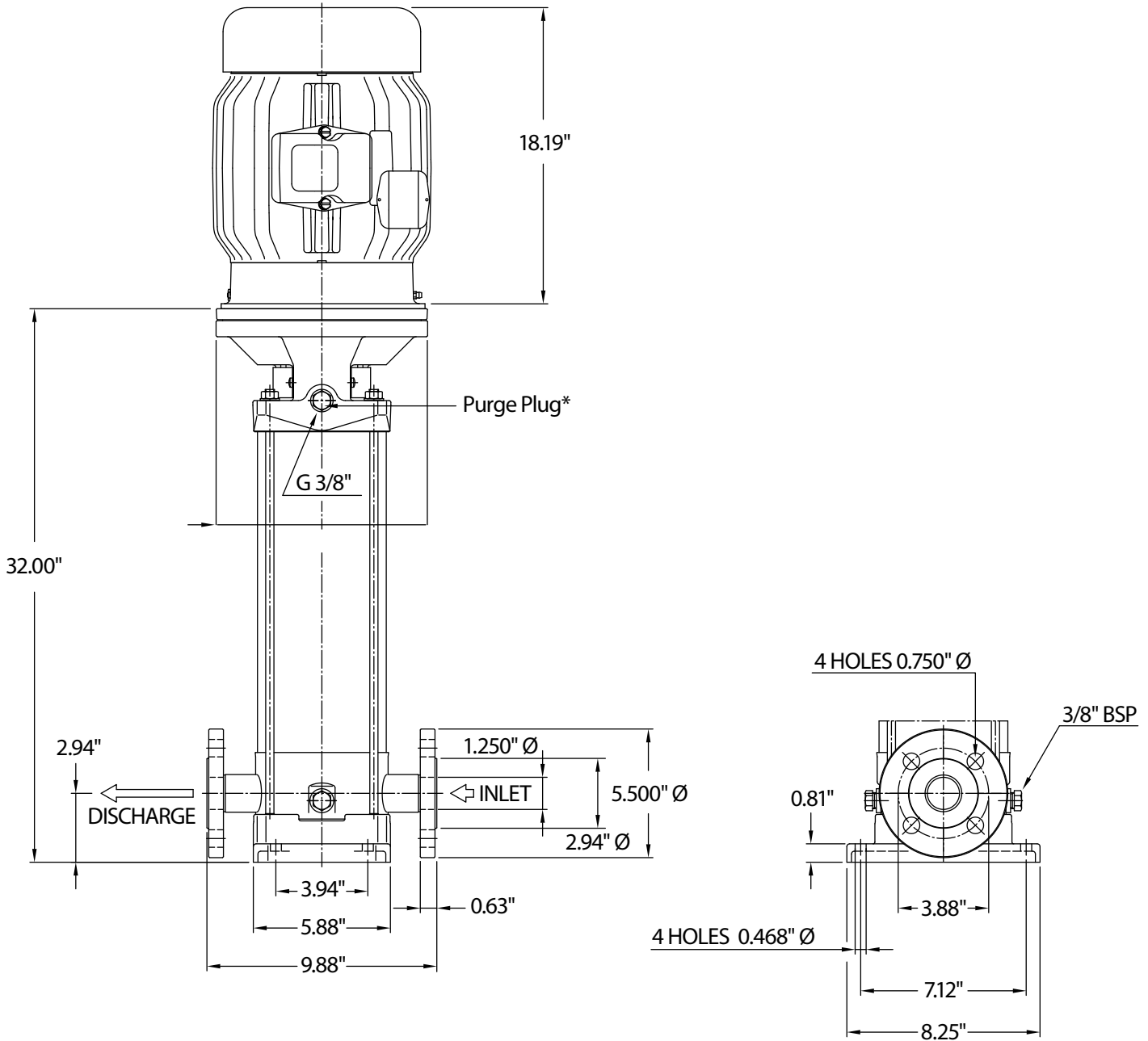

***All air must be purged out before operation to prevent seal damage.**

⚠ CAUTIONS AND WARNINGS

A bypass or pressure relief valve should be installed in the discharge line if there is any possibility the pump may operate against a closed valve in the discharge line.

Installing a bleed valve is especially necessary in hot water applications to prevent injury.

Read all CAUTIONS and WARNINGS before commencing service or operation of any high pressure system. The CAUTIONS and WARNINGS are included in the operating instructions, installation and maintenance manual. CAUTIONS and WARNINGS can also be viewed online at www.catpumps.com/cautions_warnings or can be requested directly from Cat Pumps.

WARRANTY

View the Limited Warranty on-line at www.catpumps.com/warranty.



CAT PUMPS

1681 - 94TH LANE N.E. MINNEAPOLIS, MN 55449-4324
 PHONE (763) 780-5440 — FAX (763) 780-2958
 e-mail: techsupport@catpumps.com
www.catpumps.com