

DATA SHEET

VERTICAL MULTISTAGE PUMP



**Stainless Steel
Model:**

8K5-16E0750T3



SPECIFICATIONS

Size

Suction 250# ANSI raised face 1.25"

Discharge 250# ANSI raised face 1.25"

HP 7.5 HP

RPM 3450 RPM

Liquid handled

Type of liquid Clean water (for other clean liquids, consult Cat Pumps)

Temperature 5° to +248°F (-15° to 120°C)

Working pressure 370 psi (25 bar) max.

Materials

Impeller AISI 304

Intermediate casing AISI 304

Bottom casing AISI 304

Casing cover AISI 304

Outer casing AISI 304

Shaft AISI 316

Liner ring PTFE/AISI 316

Motor bracket Cast iron/304

Base Cast iron/304

Pump Bearing Sealed ball bearing/tungsten carbide

Mechanical seal Silicon/Carbide/Carbon/FPM

Motor

Type NEMA 184TC frame

Speed 60 Hz, 3450 RPM (2 poles)

Three Phase 208-230/460V

Direction of Rotation Clockwise when viewed from motor end

Test standard ISO 9906 annex A

Weight

Pump 67.7 lbs

Motor 88.0 lbs

NOTE: See PN 99SVM001 for complete operating instructions, installation and maintenance manual information.

PERFORMANCE CURVE – 3450 RPM

42.5 gpm, 750 Ft/Hd

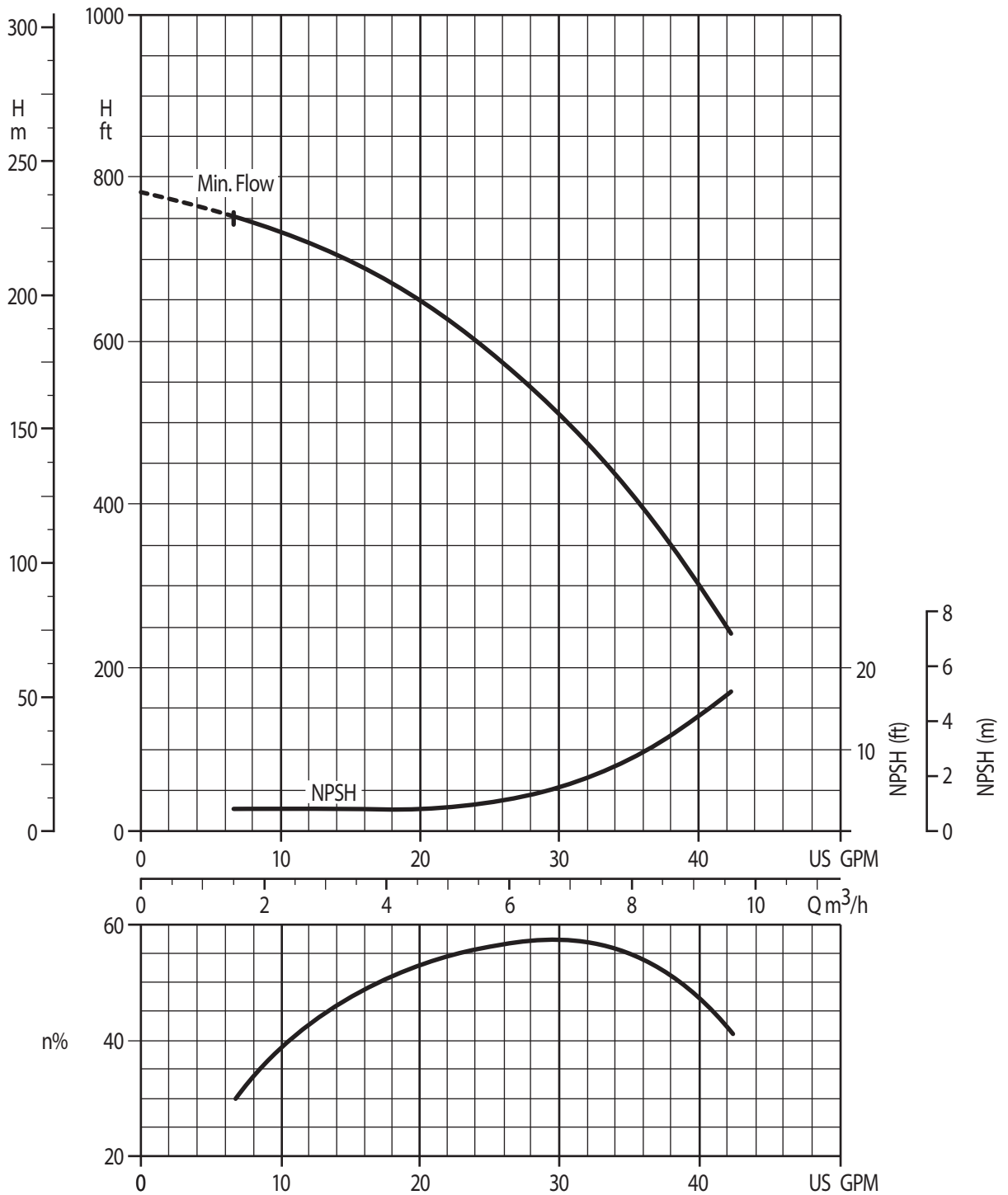

Water Temperature: 68° F (20° C)

EXPLODED VIEW

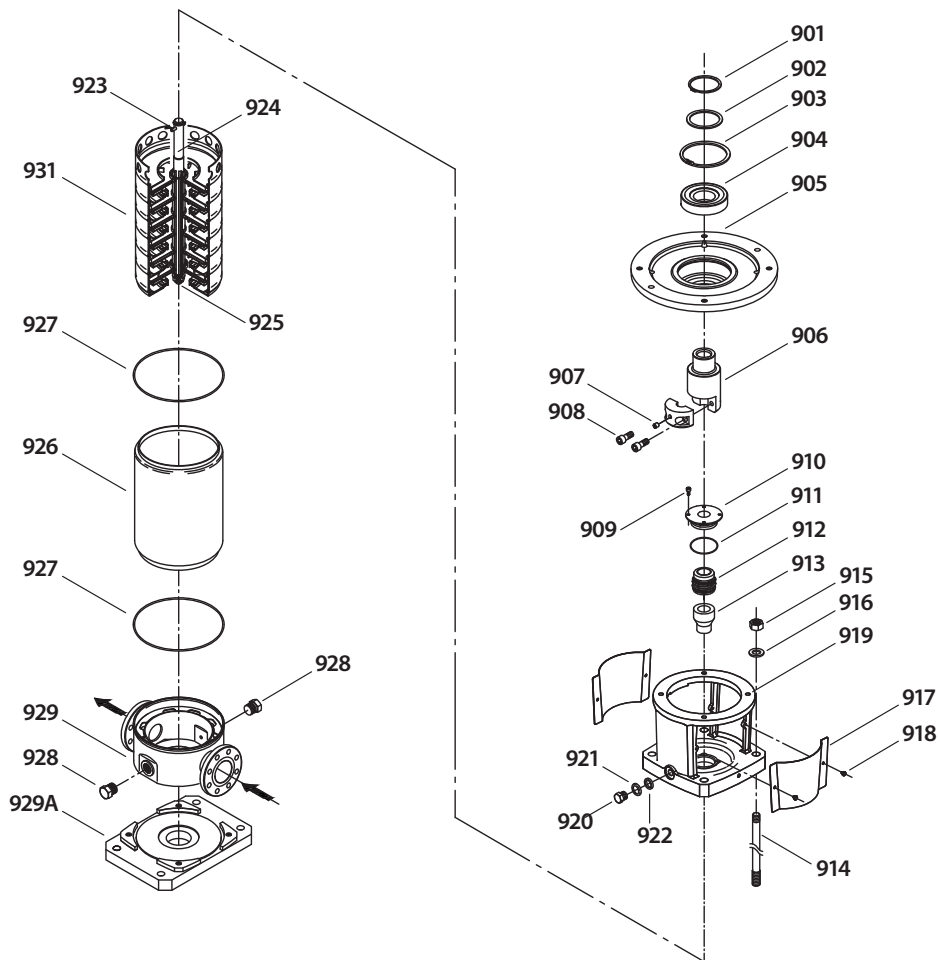

900 Motor not Shown

PARTS LIST

ITEM	PART NUMBER	MATL	DESCRIPTION	QTY	ITEM	PART NUMBER	MATL	DESCRIPTION	QTY
900	—		Motor, Electric (not shown)	1	920	—	S	Plug, Prime	1
901	—	STL	Ring, Snap, C-type for coupler	1	921	—	S	Washer, Prime Plug	1
902	—	STL	Spacer	1	922	—	FPM	O-Ring, Prime Plug	1
903	—	STL	Ring, Snap, C-type for bracket	1	923	—	STL	Pin, Shaft	1
904	—	STL	Bearing, Ball	1	924	—	SS	Shaft	1
905	—	F	Adapter, Motor	1	925	—	S	Nut, Impeller	1
906	—	BBNP	Coupling	1	926	—	S	Casting, Outer	1
907	—	STL	Screw, Set	1	927	—	FPM	O-Ring, Outer Casing	2
908	—	STZP	Screws, Coupler	2	928	—	S	Plug, Drain	2
909	—	STZP	Screws, Mechanical Seal Seat	4	929	—	S	Casing, Bottom and Base	1
910	—	S	Seat, Mechanical Seal	1	929A	—	F	Base	1
911	—	FPM	O-Ring, Mechanical Seal Seat	1	930	—	—	<i>Kit, Seal (Includes mechanical seal and 2 outer casing O-Rings)</i>	1
912	—	FSC	Seal, Mechanical	1	931	—	—	<i>Kit, Hydraulic</i>	1
913	—	S	Sleeve, Shaft	1				<i>Includes:</i>	
914	—	STZP	Rods, Tie	4				<i>Hydraulic Assembly</i>	
915	—	STZP	Nuts, Tie Rod	4				<i>Upper and lower casing o-rings</i>	
916	—	STZP	Washer, Tie Rod	4				<i>Pump shaft key</i>	
917	—	S	Guard, Coupling	2				<i>Pumps coupling snap ring</i>	
918	—	S	Screws, Coupling Guard	2				<i>Mechanical seal with o-rings</i>	
919	—	F + S	Bracket, Motor	1					

Italics are optional items

Material Codes (Not part of part number):

BBNP = Brass/Nickel Plated, F = Cast Iron, FPM = Fluorocarbon, FSC = FPM w/Silicon Carbide, S = 304 Stainless Steel, SS = 316 Stainless Steel STL = Steel, STZP = Steel/Zinc Plated

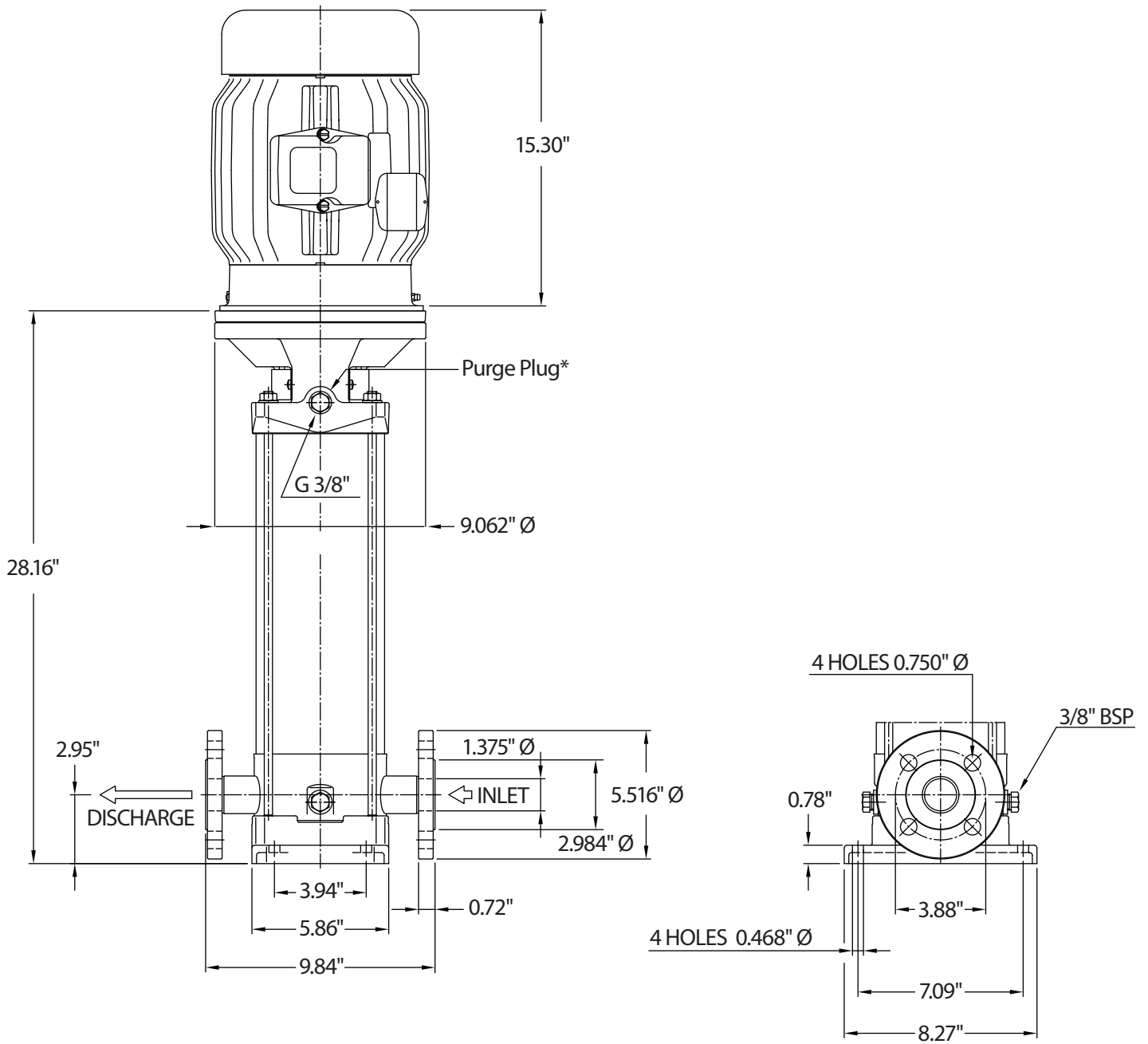

*** All air must be purged out before operation to prevent seal damage.**

⚠ CAUTIONS AND WARNINGS

All High-Pressure Systems require a primary pressure regulating device (i.e. regulator, unloader) and a secondary pressure relief device (i.e. pop-off valve, relief valve). Failure to install such relief devices could result in personal injury or damage to pump or property. Cat Pumps does not assume any liability or responsibility for the operation of a customer's high pressure system.

Read all CAUTIONS and WARNINGS before commencing service or operation of any high pressure system. The CAUTIONS and WARNINGS are included in each service manual and with each Accessory Data sheet. CAUTIONS and WARNINGS can also be viewed online at www.catpumps.com/cautions-warnings or can be requested directly from Cat Pumps.

WARRANTY

View the Limited Warranty on-line at www.catpumps.com/warranty.



CAT PUMPS

1681 - 94th Lane N.E. Minneapolis, MN 55449-4324

Phone (763) 780-5440 · Fax (763) 780-2958 · e-mail: techsupport@catpumps.com · www.catpumps.com